

QUARK
HARD DISK



Quark™
PERIPHERALS, INC.

QUARK HARD DISK DRIVE

USER'S MANUAL

for the Apple //c, Apple //e
Apple /// or Macintosh



Quark[™]
PERIPHERALS, INC.

Quark Peripherals, Inc.
2525 West Evans, Suite 220
Denver, CO 80219-5554
U.S.A.

(303) 934-2211

Revision A

Copyright Notice

This manual is copyrighted. All rights are reserved. This document may not, in whole or in part, be copied, photocopied, reproduced, translated or converted to any electronic or machine readable form without the prior written consent of Quark Peripherals, Inc.

Copyright 1984-85 Quark Peripherals, Inc.

ISBN 0-926432-07-9

ProDOS is a copyrighted program of Apple Computer, Inc. licensed to Quark Peripherals, Inc. to distribute for use in combination with the QC Hard Disk system. ProDOS shall not be copied onto another diskette (except for archive purposes) or into memory unless as part of the use of the QC Hard Disk system.

Quark, Catalyst and Word Juggler are trademarks of Quark Incorporated.

Apple, ProDOS, SOS, DuoDisk, and MacPaint are registered trademarks of Apple Computer, Inc.

Macintosh is a trademark licensed to Apple Computer by McIntosh Laboratories, Inc.

Portions of the QC hard disk hardware are licensed to Quark Peripherals, Inc. by ALF Products, Inc.

The following notice is required by Apple Computer, Inc. It applies only to Apple software. All other software is covered by Quark's limited warranty.

APPLE COMPUTER, INC. MAKES NO WARRANTIES, EITHER EXPRESS OR IMPLIED, REGARDING THE ENCLOSED COMPUTER SOFTWARE PACKAGE, ITS MERCHANTABILITY OR ITS FITNESS FOR ANY PARTICULAR PURPOSE.

LIMITED WARRANTY

Quark Peripherals Inc. warrants this product against defects in materials and workmanship for a period of 90 days from the original date of purchase to the original purchaser only. The warranty is valid only if the Warranty Registration card is returned to Quark. Also, no warranty coverage will be provided in the event that the product has been used prior to its sale to the original purchaser.

During the warranty period, Quark will repair or replace (at its option) at no charge, any components that prove to be defective, provided the defective component is returned (shipping prepaid and properly packed) to Quark Peripherals Inc. Proof of purchase date must accompany any request for warranty service.

This warranty does not apply if, in the opinion of Quark, the product has been damaged by accident, misuse, or neglect or has been subjected to modifications other than those prescribed in this manual.

This warranty is in lieu of all other express or implied warranties, statements or representations. All implied warranties, including those of merchantability or fitness for a particular purpose, are also limited to a 90 day duration from date of original purchase. Some states do not allow limitations on how long an implied warranty lasts, so this limitation may not apply to you.

In the event that this product should prove defective, your sole remedy shall be the repair or replacement of the defective components as stated above. Quark will not be liable for any incidental or consequential damages arising from use of this product. Some states do not allow the exclusion of incidental or consequential damages, so this limitation may not apply to you.

This warranty gives you specific legal rights and you may have other rights which vary from state to state.

Radio and Television Interference

The equipment described in this manual generates and uses radio frequency energy, and if not installed and used in accordance with the instructions in this manual, may cause interference to radio and television reception.

The equipment has been tested and complies with the limits for a Class B computing device in accordance with the specifications in Subpart J of Part 15 of FCC Rules. These rules are designed to provide reasonable protection against such interference in a residential installation. However, there is no guarantee that interference will not occur in a particular installation.

If this equipment does cause interference to radio or television reception, which can be determined by turning the equipment off and on, the user is encouraged to try to correct the interference by one or more of the following measures:

- Reorient the radio or television receiving antenna.
- Relocate the computer equipment with respect to the receiver.
- Plug the computer equipment into a different outlet, so the equipment and receiver are on different branch circuits.

If necessary, the user should consult the dealer or an experienced radio/television technician for additional suggestions. The user may find the following booklet prepared by the Federal Communications Commission helpful:

"How to Identify and Resolve Radio-TV Interference Problems"

This booklet is available from the U.S. Government Printing Office, Washington, DC 20402, stock number 004-000-00345-4.

In order to comply with FCC regulations, the user is instructed to use only those shielded cables supplied with the equipment.

TABLE OF CONTENTS

Chapter 1 - Introduction

Using This Manual	1-1
Overview	1-2
System Requirements	1-2
Operating System Environment Support	1-3
Volume Support	1-3
Catalyst Program Selector	1-4
Unpacking Your Hard Disk Drive	1-5
Repair and Replacement	1-5
Shipping Diskettes	1-6
Updates and Upgrades	1-6
The Quark Courant	1-7
Comments and Suggestions	1-7

Chapter 2 - Hardware Installation

Overview	2-1
Installation on the Apple //c	2-3
Installation on the Apple //e	2-6
Installation on the Apple /// and ///+	2-13
Installation on the Macintosh	2-17

Chapter 3 - Preparing To Use Your QC Hard Disk

Powering Up Your System	3-1
Checking Out the Hard Disk	3-2
Operating Your Drive	3-2
Backing Up Your Hard Disk Files	3-3
Caring For Your Drive	3-3
If Your Drive Doesn't Work	3-4

Chapter 4 - Software Installation

Installation on the Apple //c and //e	4-1
Overview	4-1
QC Hard Disk Utilities	4-4
Install Driver	4-5
Edit Slot/Drive Assignments	4-7
Volume Manager	4-9
Filer	4-9
Start Application	4-9
Quit	4-10
Using Catalyst With the QC Hard Disk	4-10
Volume Manager Installation Under Catalyst	4-11

Chapter 4 (continued)

Installation on the Apple /// and ///+	4-12
Overview	4-12
Installing the Device Drivers	4-13
The Volume Manager	4-14
Using Catalyst With the QC Hard Disk	4-14
Volume Manager Installation Under Catalyst	4-15
Installation on the Macintosh	4-16
Overview	4-16
Installing the Device Drivers	4-17
The Volume Manager	4-17

Chapter 5 - Operating Environment

Overview	5-1
Using the QC Hard Disk Under ProDOS	5-1
Using the QC Hard Disk Under SOS	5-2
Using the QC Hard Disk With Macintosh.	5-3
Performance	5-3

Chapter 6 - The Volume Manager

Overview	6-1
Access Restrictions	6-2
Volume Names	6-3
Volume Type	6-4
Apple //c, //e, and /// Volume Manager	6-5
Create Volumes	6-6
Catalog of Volumes	6-8
Edit Current Mounts	6-9
Edit Automatic Mounts	6-11
Delete Volumes	6-12
Edit Volume Characteristics	6-13
Utilities	6-15
Quit	6-15
Macintosh Volume Manager	6-16
Creating New Volumes	6-17
Editing Current Mounts	6-18
Editing Automatic Mounts	6-19
Deleting Volumes	6-20
Editing Volume Characteristics	6-20
Miscellaneous Functions	6-22
Quit	6-22
Desk Accessories	6-22

Appendix A - Error Messages

Apple //c, //e, and /// Volume Manager	A-1
Apple //c and //e QC Hard Disk Utilities	A-3
Macintosh Volume Manager	A-6

When you purchased your QC hard disk drive, you should have received all components listed on the packing list included with the drive. If you did not receive all of the components, return the product **immediately** to your dealer to obtain the missing parts.

IMPORTANT: Warranty service cannot be provided unless you fill out and return the Warranty Registration card. Send the card in immediately. It is the only mechanism we have for providing warranty service and of informing you about updates to the QC hard disk and its associated software, new products and improved versions of the QC hard disk system.

Using This Manual

Chapter 1 introduces you to the QC hard disk system and explains Quark's service and repair policy.

Chapter 2 contains detailed information for performing the hardware installation of the physical components of the QC hard disk on your system.

Chapter 3 explains how to apply power to the hard disk and verify that it is operating properly. This chapter also includes information on the care and handling of your drive, and for backing up your QC files.

Chapter 4 contains detailed information for performing the installation of the QC disk drivers and supporting software.

Chapter 5 describes how the QC hard disk can be used with various operating systems.

Chapter 6 describes the Volume Manager, which may be used to partition your QC hard disk into separate volumes of data.

Appendix A lists all error messages that the Volume Manager and QC Hard Disk Utilities program may produce and describes each one. Pointers are given on how to avoid certain errors.

Overview

The QC hard disk is a highly reliable data storage system which will greatly increase the overall capabilities of your computer. Packaged in a physically small area, the QC hard disk provides a substantial amount of additional disk storage space which can be accessed by your computer much more quickly than ordinary floppy diskettes.

The QC hard disk storage system consists of a fixed-media, random-access disk drive, disk controller card, host adapter card and power supply packaged together in a lightweight, compact cabinet. The QC hard disk system is a Winchester-type device, meaning that its read/write heads, disks, and actuator mechanism are integrated in a sealed, protective, non-removable housing.

The QC hard disk differs from a conventional floppy diskette drive in that its media, consisting of hard disks rather than flexible diskettes, cannot be interchanged.

The main advantages hard disk systems have over floppy diskette drives include much greater data storage capability, higher reliability, and improved performance. Since the media in the QC hard disk are protected by a sealed, non-removable housing, they cannot be damaged or lost as floppy diskettes can.

The QC hard disk is very portable, and if handled with care, can be readily moved from one location to another. The QC hard disk will easily stack on top of an Apple //e computer or DuoDisk floppy disk drive. As a general rule, you should place the drive on a hard surface where it is convenient to operate, and air flow is not restricted around the unit.

System Requirements

On the Apple //e, the QC hard disk system requires at least 128K of memory. The hard disk must also interface to your system through an Apple Disk II or DuoDisk controller card.

On the Apple ///+, the QC hard disk system requires an Apple /// to Apple ///+ disk connector converter (Apple part number A3M0105). If your ///+ includes a Disk /// external diskette drive, you should already have this converter.

The QC hard disk system will not work with the Apple // or Apple //+ computers.

With the current hardware revision, the Macintosh external disk drive may not be used with the QC hard disk system.

Operating System Environment Support

The QC hard disk drive may be readily used under Apple's Professional Disk Operating System (ProDOS) on the Apple //c and Apple //e computers, under the Sophisticated Operating System (SOS) on the Apple ///, and with Macintosh as well. Driver software for interfacing the disk drive to these systems is supplied on diskettes included with the unit.

After installing your QC hard disk and its associated driver software, normal ProDOS, SOS, or Macintosh commands may be issued to perform the same type of operations possible with conventional floppy diskettes. These operations include changing volume names, obtaining catalog listings, saving and deleting files, etc. The disk utility programs supplied with your computer (including the ProDOS Filer, SOS's System Utilities, etc.) may also be used with your QC disk drive.

Volume Support

Your QC hard disk can be organized as a single drive, or may be partitioned into smaller storage areas called "volumes". A volume is an area of data storage which is treated as a separate disk. You may create up to 63 different volumes on your QC hard disk drive. The motivations for partitioning one physical drive into several different volumes include:

- Different applications or languages can be placed on separate volumes. You may then access only the volumes required for the application or language you wish to use.
- Separate areas for different operating systems may be defined. You could, for example, reserve 5 megabytes for your Apple //c, 3 megabytes for your Apple ///, and 2 megabytes for Macintosh. The appropriate volume may be accessed depending on which machine you connect to your QC hard disk.

- A "floppy equivalent" sized volume may be created. This could be utilized to quickly copy files to or from floppy diskettes using the "Volume Copy" command (much faster than transferring individual files) available through your disk utilities program.
- "Scratch area" volumes may be defined for data which is transitory in nature. These volumes may be readily formatted or deleted without disturbing the data in other volumes on the disk.
- Since access to individual volumes may be selectively granted through the use of passwords, sensitive data can be placed on separate volumes distinct from those required by most users of your system. Volumes may also be configured to permit data to be read by some users and written by others.

Volumes may be selectively mounted (connected to your system) or unmounted and individually accessed as required. Volumes may also be defined to be automatically mounted on your system when it is first booted.

Catalyst Program Selector

The full power of your QC hard disk system may be realized when you use Quark's Catalyst program selector for the Apple //c, //e, and /// computers.

Catalyst provides you with a convenient method for putting your ProDOS or SOS programs on the hard disk, and for accessing them without rebooting your machine when you switch from one application to another.

Once installed, Catalyst gives you a simple menu-driven mechanism for selecting which program you wish to use. Catalyst will automatically run the program you select. And when you are ready to go on to something else, a few simple keystrokes return you to the Catalyst menu, all without ever using a floppy diskette.

Unpacking Your Hard Disk Drive

Your QC hard disk comes packaged in a cardboard shipping carton and is protected by thick foam padding material. Save the carton and all packing material in case you wish to ship your drive. Serious damage may result if you attempt to transport the drive without proper packing. You **must** return the QC hard disk to Quark packed in its original shipping carton if warranty service is ever required.

When you first open the shipping carton, you will find a small cardboard box containing a packing list, this manual, power and interface cables, diskettes containing drivers and other software, tools for QC disk installation, and other important documents. As you unpack the carton, check your packing list to ensure you have received all items listed.

Your QC hard disk is a delicate instrument. **Handle with care** when removing your disk from the shipping carton. Extensive damage may result if the unit is accidentally bumped, jarred, dropped, or handled roughly.

After removing the QC accessories box, reach down with both hands, and pull the drive and its protective foam padding straight upward and out of the carton. Remove the padding from the ends of the drive, and pull the disk out of its plastic wrapper. Place your QC hard disk on a flat surface in the area where you intend to operate your computer.

Repair and Replacement

The Limited Warranty covering this product is given at the beginning of this manual. Read it carefully. Basically it says this: If within 90 days of purchase your QC hard disk or its associated software fails to function properly through some error on our part, we will either repair or replace the defective component(s) at our option.

Defective diskettes should be returned to Quark postpaid and properly packed (see below). A defective hard disk drive must be returned postpaid and packed properly in its original shipping carton. Damage caused during shipping due to improper packing will void your warranty.

Before returning the QC hard disk, make sure its read/write heads have been retracted to the shipping zone, as explained in Chapter 6.

Returns must be accompanied by the following:

1. Proof of purchase and purchase date.
2. A description of the problem and its cause.
3. A description of the system on which the hard disk is being used (amount of memory, peripherals attached, cards installed, etc.).
4. Your Warranty Registration card if you haven't sent it in already.

This applies only to the original purchaser, and does not apply to any product which has been used prior to its sale by any dealer or distributor.

In the event that we have not received the Warranty Registration card, no warranty service will be provided. If your warranty has expired or been voided, you will be billed for parts, labor and return shipping costs.

Shipping Diskettes

When mailing a diskette, do not just put it in a plain envelope. Even a padded envelope is not sufficient. The post office has a tendency to bend things. This generally destroys diskettes.

You should sandwich the diskette between two pieces of **corrugated** cardboard and then put it in an envelope. Write the magic incantation "DO NOT BEND" on both sides of the envelope. Alternatively you may purchase special diskette mailers from your local dealer, such as the Floppy Box from ALF Products.

Updates and Upgrades

Fill out and mail in the Warranty Registration card supplied with your QC hard disk. If it becomes necessary for Quark to provide corrected software for your hard disk, you will be notified of any errors being fixed and any new features which you may get as a side effect. Instructions describing the return procedure will be included with the notification.

The Quark Courant

The Warranty Registration card will also put you on the mailing list for the Quark Courant, our quarterly newsletter. The Courant contains information on new products and product upgrades as well as hints on using Quark products and other information of general interest.

Comments and Suggestions

If you have suggestions for changes or improvements in this product, or suggestions for a new product, just drop us a line. Your comments are always welcome.

Quark Peripherals, Inc.
2525 West Evans, Suite 220
Denver, CO 80219-5554
U.S.A.

Overview

In order to prepare for the hardware installation of your QC hard disk, move the unit to a convenient location near your computer. This location should be in a cool, relatively dust free area. Do not set the drive on a thick carpet or any other surface which might obstruct air flow around the unit.

The hardware installation of your QC hard disk drive basically consists of connecting the disk to your computer's floppy diskette port using one or more of the supplied interface cables shown in Figure 2-1, and providing a power source to the unit.

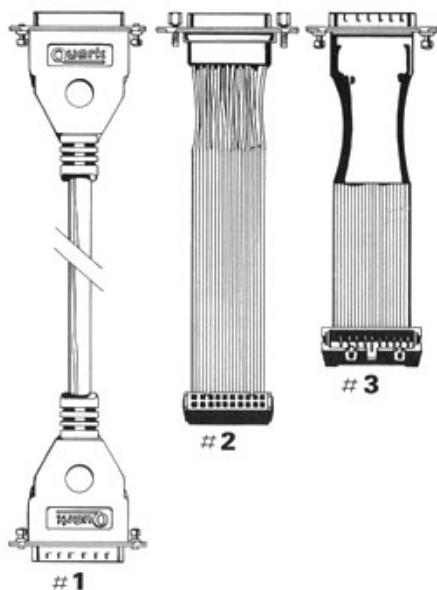

Figure 2-1. Supplied Interface Cables

Your QC hard disk is equipped with a three-wire power cord which is designed to fit only into a polarized, grounded three-hole outlet. If such an outlet is unavailable, have one installed by a licensed electrician, or use a three to two prong adapter. If you use such an adapter, you **must** attach the ground wire. Do not attempt to defeat the purpose of the grounding-type plug!

Before beginning the hardware installation procedure, make sure that all power to your entire computer system is OFF. Turn off all power switches on the back of your computer, the QC hard disk, and all other peripheral devices attached to your system.

It is recommended that all of your computer equipment be plugged into the same circuit as well, as a precaution to avoid possible "ground loop" problems.

The procedure for installing your QC hard disk will differ slightly for different computers. You need be concerned only with the section that pertains to the installation on your particular computer.

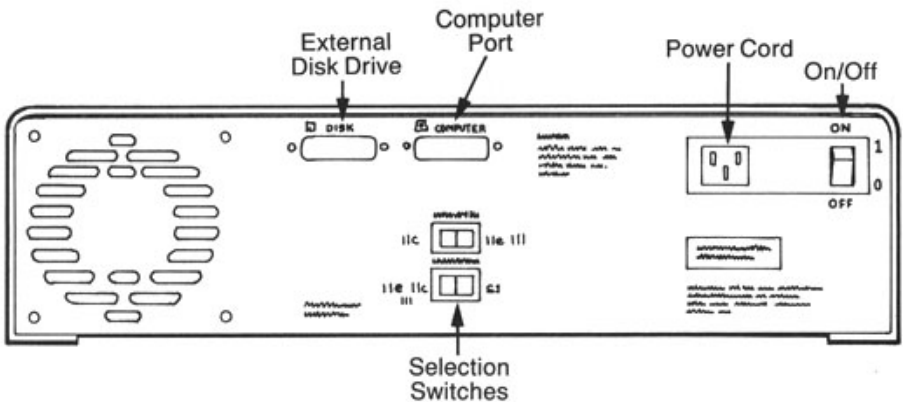

Figure 2-2. Rear View of the QC Hard Disk

Installation on the Apple IIc

To install the QC hard disk on the Apple //c, you will need the following components:

- The Quark cable labeled "#1" in Figure 2-1.
- Quark screwdriver.
- Power cord.

Before proceeding with the installation instructions, read over this entire section. Serious damage may occur to the QC hard disk or to your computer if the drive is not correctly installed.

1. Turn OFF the power switches on the rear of the computer, the QC hard disk drive, and on any other attached peripheral devices.
2. If your system has an Apple //c external diskette drive attached, disconnect it from the external floppy socket on the back of the computer.
3. Connect the male end of the Quark cable to the external floppy socket and tighten the screws. This socket is a nineteen-hole "D"-shaped connector, identified with a diskette icon. The connector will allow the cable to be plugged into the socket in only one direction.
4. Connect the other end of the Quark cable to the nineteen-pin "D"-shaped socket labeled "Computer" on the back of the QC hard disk, and tighten the screws as illustrated in Figure 2-3.
5. If you removed an Apple //c external drive in step 2, connect its cable to the nineteen-hole "D" shaped socket labeled "Disk" on the back of the QC hard disk, and tighten the screws.
6. Your hardware configuration so far (assuming you connected an Apple //c external diskette drive in step 5) should appear as illustrated in Figure 2-4.
7. Set the rocker switches on the back of the QC hard disk so that both are in the //c position as in Figure 2-5.
8. Connect the mating plug on the power cord into the recessed 3-pin AC power connector on the back of the QC hard disk. The plug can be inserted in only one direction.

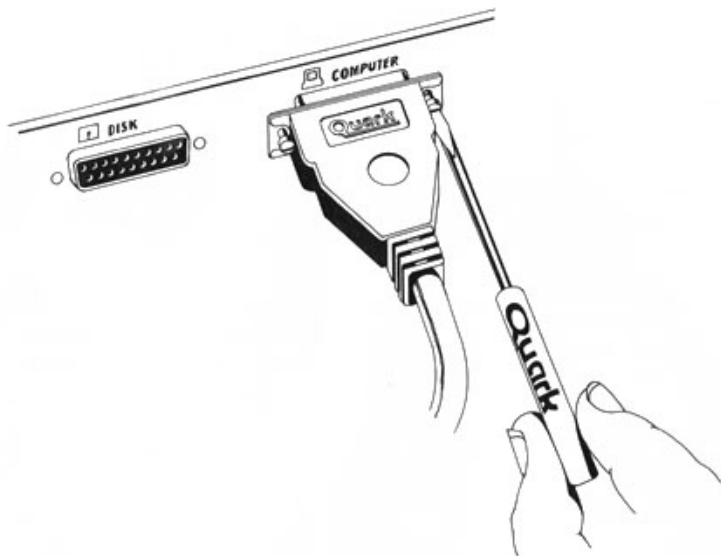

Figure 2-3. Connecting Quark Cable to QC Hard Disk



Figure 2-4. Hardware Configuration (Apple //c)

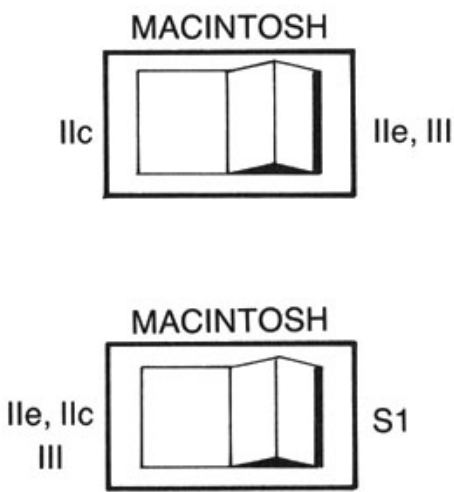

Figure 2-5. Rocker Switch Settings (Apple //c)

When you are satisfied that you have correctly installed the QC hard disk on your computer, proceed to Chapter 3 where you will learn how to power up, check out, and operate your system.

Installation on the Apple IIe

To install the QC hard disk on the Apple IIe with a Disk II floppy diskette drive (but no DuoDisk), you will need the following components:

- The Quark cable labeled "#1" in Figure 2-1.
- Interface cables labeled "#2" and "#3" in Figure 2-1.
- Female screw lock kit.
- The small hex wrench.
- Quark screwdriver.
- Power cord.

To install the QC hard disk on the Apple IIe with a DuoDisk floppy diskette drive, you will need the following components:

- The Quark cable labeled "#1" in Figure 2-1.
- Quark screwdriver.
- Power cord.

Before proceeding with the installation instructions, read over this entire section. Serious damage may occur to the QC hard disk or to your computer if the drive is not correctly installed.

Your QC hard disk comes preconfigured to interface to the Apple IIe through an Apple Disk II or DuoDisk type controller card in **Slot 6**. These installation instructions assume you will be using this standard configuration. If your system is not set up in this manner, you must change the configuration using the Utilities program supplied with your hard disk (see Chapter 4).

1. Turn OFF the power switches on the rear of the computer, the QC hard disk drive, and on any other attached peripheral devices.
2. Pull up on the two back corners of the computer's cover until the corner fasteners pop apart. Carefully remove the cover and set it aside.
3. Look inside your computer and locate the power supply, the rectangular metal box along the left side. Touch the power supply case with one hand to discharge any static charge that may be on your clothes or body.
4. If your system has a DuoDisk controller card in Slot 6, skip to step 15.

5. Locate your Disk II floppy diskette drive's interface cable connected to the disk controller card in Slot 6 (the cable should be plugged into the socket labeled "Drive 1" on the card). Disconnect the cable from the controller card by pulling the rectangular connector straight up and out of its socket. Remove the Disk II drive and its cable assembly from the computer.
6. We will now attach the "D"-shaped connector on the interface cable labeled "#2" in Figure 2-1 to the back panel opening nearest the disk controller card in your computer. Note that the nearest opening that will accommodate this connector is labeled "4" on the back of your computer. Before you can attach the connector, you must remove the protective plastic cover plate from the opening by reaching inside the computer and pushing down and out on the tab on the back of the plate.
7. Remove the contents of the female screw lock kit. Insert one of the screw locks into the "D"-shaped connector's mounting hole and finger-tighten a couple of turns in a clockwise direction.
8. Insert the "D"-shaped connector from inside the computer through the back panel opening as shown in Figure 2-6. The screw lock should be seated in the small notch in the back panel opening, and the hex shaped screw lock head should protrude out the back of the case.

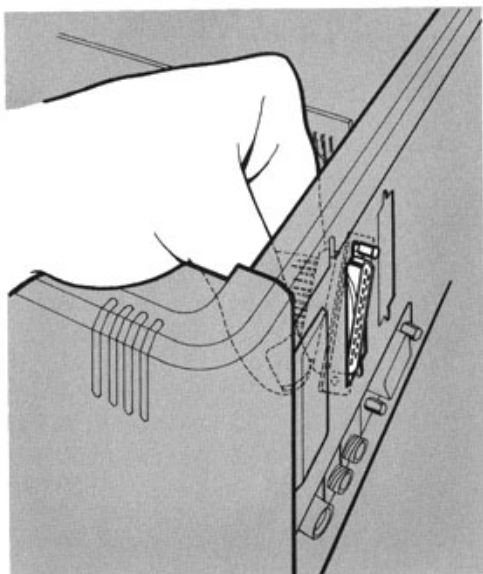

Figure 2-6. Positioning Connector In Back Panel

9. Insert the other screw lock into the "D"-shaped connector's remaining mounting hole from the back of the computer as illustrated in Figure 2-7. Tighten both screw locks using the small hex wrench.

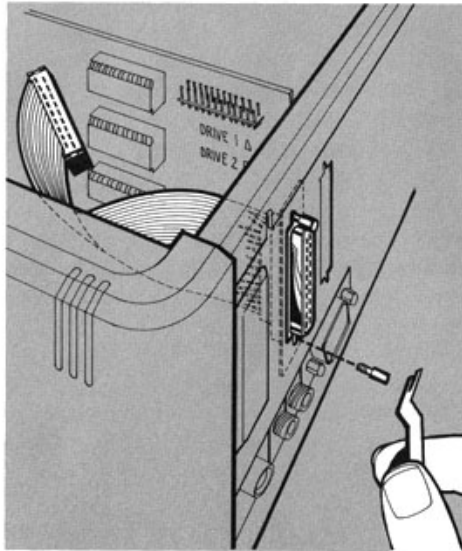

Figure 2-7. Tightening Interface Connector Screw Locks

10. Plug the other end of this cable assembly into the disk controller card socket referenced in step 5, as illustrated in Figure 2-8.
11. Connect the male end of the Quark cable to the back panel "D"-shaped connector just installed, and tighten the screws. The "D"-shaped connector will allow the cable to be plugged into the socket in only one direction.
12. Connect the other end of the Quark cable to the nineteen-pin "D"-shaped socket labeled "Computer" on the back of the QC hard disk, and tighten the screws as illustrated in Figure 2-9.
13. Push the rectangular plug on your Disk II floppy diskette drive into the rectangular socket of the interface cable labeled "#3" in Figure 2-1. Connect the "D"-shaped connector on the other end of this cable to the nineteen-hole "D"-shaped socket labeled "Disk" on the back of the QC hard disk. Tighten the screws.

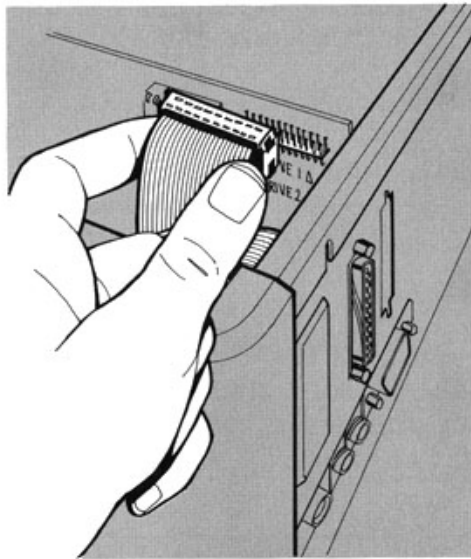

Figure 2-8. Connecting Cable to Disk Controller Card

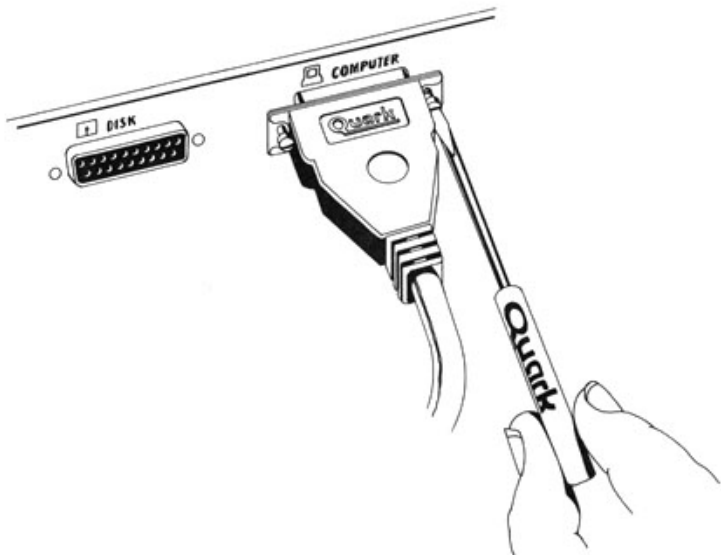

Figure 2-9. Connecting Quark Cable to QC Hard Disk

14. Your hardware configuration so far should appear as illustrated in Figure 2-10. Now, skip to step 20.

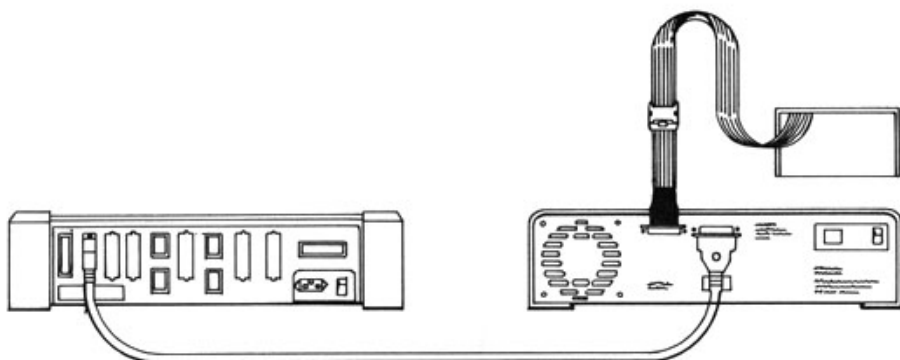

Figure 2-10. Hardware Configuration (Apple //e with Disk II)

15. If your system has a DuoDisk controller card in Slot 6, disconnect the interface cable between the DuoDisk and its controller card's "D"-shaped connector on the back panel of your computer.
16. Connect the male end of the Quark cable to this back panel connector, and tighten the screws. The "D"-shaped connector will allow the cable to be plugged into the socket in only one direction.
17. Connect the other end of the Quark cable to the nineteen-pin "D"-shaped socket labeled "Computer" on the back of the QC hard disk, and tighten the screws as illustrated in Figure 2-9.
18. Connect the free end of the DuoDisk interface cable (disconnected in step 15) to the nineteen-hole "D"-shaped socket labeled "Disk" on the back of the QC hard disk, and tighten the screws.
19. Your hardware configuration so far should appear as illustrated in Figure 2-11.

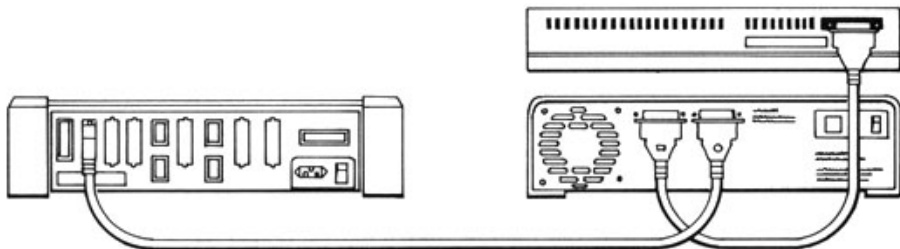

Figure 2-11. Hardware Configuration (Apple //e with DuoDisk)

20. Set the rocker switches on the back of the QC hard disk so that both are in the //e position as in Figure 2-12.

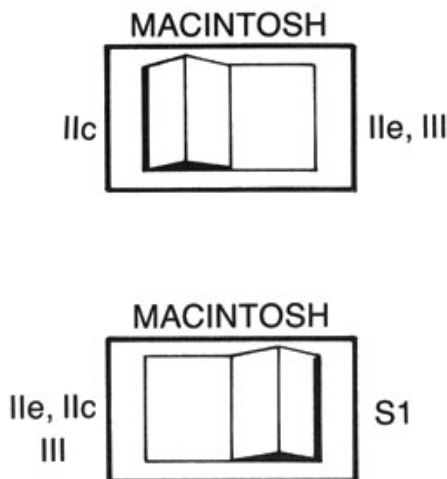

Figure 2-12. Rocker Switch Settings (Apple //e)

21. Connect the mating plug on the power cord into the recessed 3-pin AC power connector on the back of the QC hard disk. The plug can be inserted in only one direction.

When you are satisfied that you have correctly installed the QC hard disk on your computer, proceed to Chapter 3 where you will learn how to power up, check out, and operate your system.

Installation on the Apple III and III +

To install the QC hard disk on the Apple ///, you will need the following components:

- The Quark cable labeled "#1" in Figure 2-1.
- The Apple /// QC hard disk interface cable shown in Figure 2-13. This cable may be obtained free of charge by contacting Quark Peripherals, Inc.
- Quark screwdriver.
- Power cord.



Figure 2-13. Apple /// QC Hard Disk Interface Cable

To install the QC hard disk on the Apple ///+, you will need the following in addition to the above components:

- An Apple /// to Apple ///+ disk connector converter (Apple part number A3M0105). If your system includes Disk /// external disk drives, they should already be interfaced to your computer through such a converter. An additional converter will not be necessary.

Before proceeding with the installation instructions, read over this entire section. Serious damage may occur to the QC hard disk or to your computer if the drive is not correctly installed.

1. Turn OFF the power switches on the rear of the computer, the QC hard disk drive, and on any other attached peripheral devices.
2. Plug the rectangular end of the Apple /// QC hard disk interface cable into the external floppy socket on the back of the computer. This connector is keyed to permit insertion in only one direction.

If your system has Disk /// external floppy diskette drives, plug the hard disk interface cable into the last external drive instead. Up to two external diskette drives may be daisy-chained **between** the computer and hard disk drive.

If you have an Apple ///+ with no external diskette drives, plug the rectangular end of the Apple /// interface cable into the A3M0105, and then plug this converter into the external floppy socket on the back of the computer.

3. Plug the male end of the Quark cable into the "D"-shaped connector of the Apple /// QC hard disk interface cable.
4. Connect the other end of the Quark cable to the nineteen-pin "D"-shaped socket labeled "Computer" on the back of the QC hard disk, and tighten the screws as illustrated in Figure 2-14.

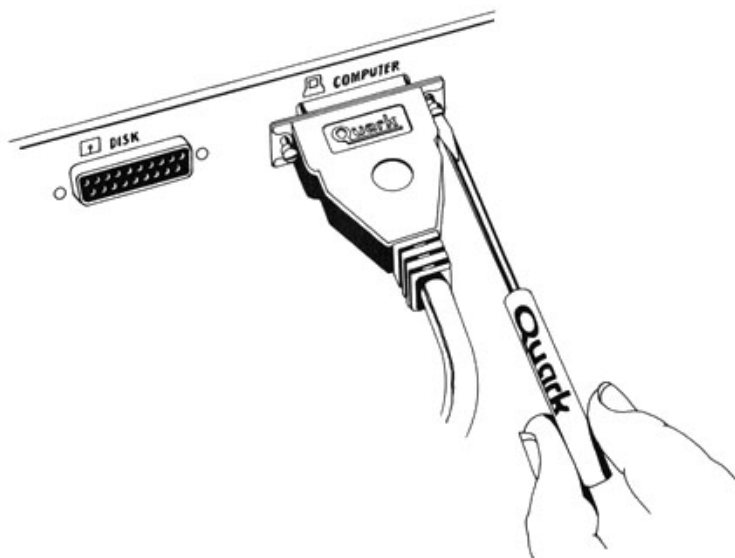

Figure 2-14. Connecting Quark Cable to QC Hard Disk

5. Your hardware configuration so far (assuming your system has no external diskette drive(s) described in step 2) should appear as illustrated in Figure 2-15.

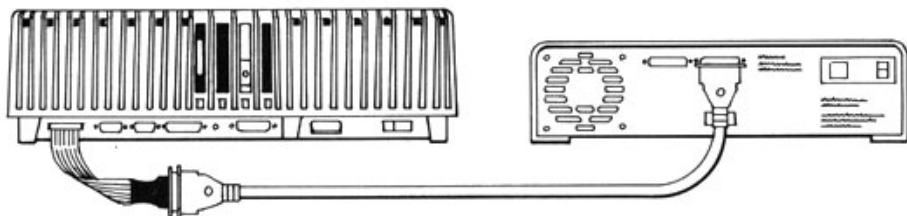

Figure 2-15. Hardware Configuration (Apple ///)

6. Set the rocker switches on the back of the QC hard disk so that both are in the /// position as in Figure 2-16.

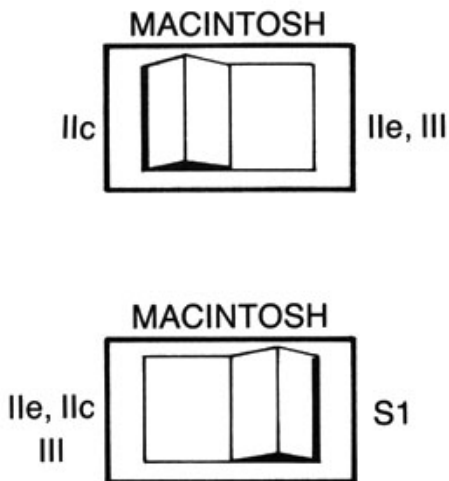

Figure 2-16. Rocker Switch Settings (Apple ///)

7. Connect the mating plug on the power cord into the recessed 3-pin AC power connector on the back of the QC hard disk. The plug can be inserted in only one direction.

When you are satisfied that you have correctly installed the QC hard disk on your computer, proceed to Chapter 3 where you will learn how to power up, check out, and operate your system.

Installation on the Macintosh

To install the QC hard disk on the Macintosh, you will need the following components:

- The Quark cable labeled "#1" in Figure 2-1.
- Quark screwdriver.
- Power cord.

Before proceeding with the installation instructions, read over this entire section. Serious damage may occur to the QC hard disk or to your computer if the drive is not correctly installed.

1. Turn OFF the power switches on the rear of the computer, the QC hard disk drive, and on any other attached peripheral devices.
2. If your system has an external floppy disk drive attached, disconnect it from its socket on the back of the computer. The QC hard disk system does not presently support the external Macintosh disk drive.
3. Connect the male end of the Quark cable to the external disk drive socket on the back of the computer and tighten the screws. This socket is a nineteen-hole "D"-shaped connector with a disk drive icon above it. The connector will allow the cable to be plugged into the socket in only one direction.
4. Connect the other end of the Quark cable to the nineteen-pin "D"-shaped socket labeled "Computer" on the back of the QC hard disk, and tighten the screws as illustrated in Figure 2-17.
5. Your hardware configuration so far should appear as illustrated in Figure 2-18.
6. Set the rocker switches on the back of the QC hard disk so that both are in the center Macintosh position as illustrated in Figure 2-19.
7. Connect the mating plug on the power cord into the recessed 3-pin AC power connector on the back of the QC hard disk. The plug can be inserted in only one direction.

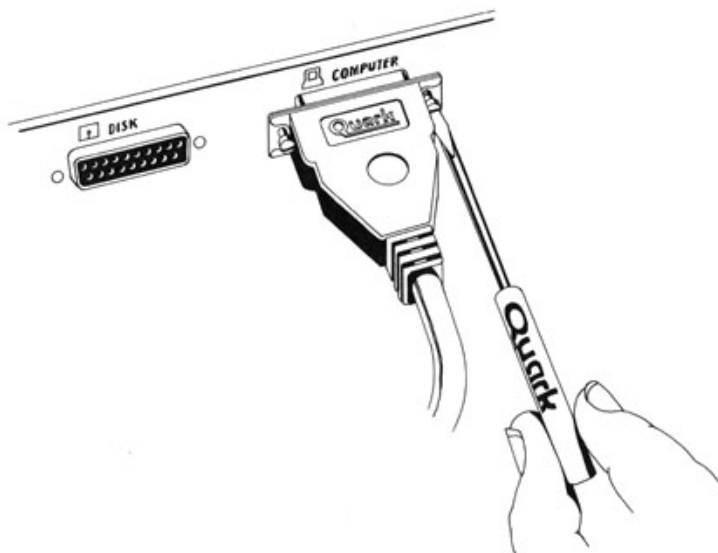

Figure 2-17. Connecting Quark Cable to QC Hard Disk

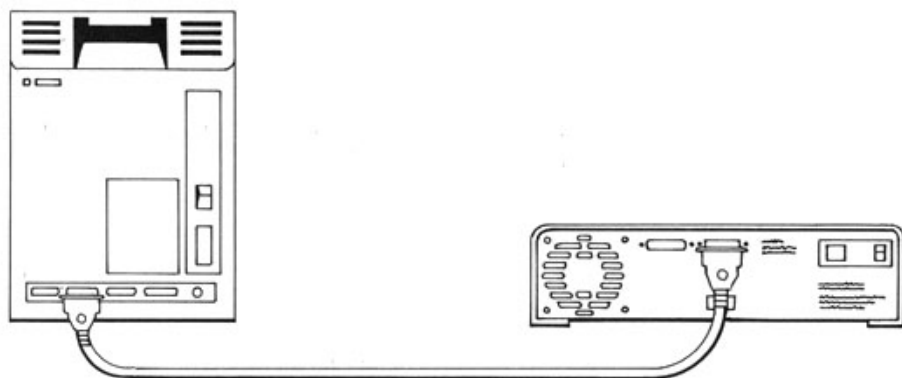

Figure 2-18. Hardware Configuration (Macintosh)

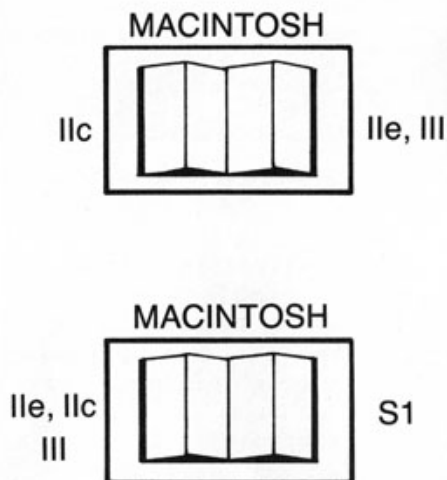

Figure 2-19. Rocker Switch Settings (Macintosh)

When you are satisfied that you have correctly installed the QC hard disk on your computer, proceed to Chapter 3 where you will learn how to power up, check out, and operate your system.

CHAPTER THREE

PREPARING TO USE YOUR QC HARD DISK

Powering Up Your System

Now that the hardware installation of your QC hard disk has been completed, you may plug in the power cord for the drive. It is recommended that all of your computer equipment be plugged into the same circuit. This is a precaution to avoid possible "ground loop" problems.

WARNING: It is especially important that you do not turn on the hard disk if the unit is too cold (for example, after being left outside in a car overnight). Wait for the hard disk to warm up to room temperature before applying power.

Turn on the AC power switch on the back of the drive. You should hear the disk drive and ventilation fan motors start up. The red disk access light on the lower right corner of the front of the unit should flash once and then go out while the disk drive is brought up to speed.

The drive should be ready for operation in about ten seconds, and the disk access light should be extinguished. If the disk access light flashes on and off periodically after the initial power up, your unit may be experiencing problems. Turn the hard disk off, wait a few seconds, and repeat the power up sequence. If the disk access light continues to flash on and off after power up, contact Quark Peripherals, Inc. for service information.

To minimize the possibility of equipment failure, it is recommended that you turn off the hard disk only if you aren't planning to use it for an extended period of time.

Never turn off the hard disk when the drive is being accessed by your computer (red disk access light flashing), or while a program is in operation. Make sure the red disk access light is off for at least five seconds before turning off the unit.

Checking Out the Hard Disk

After your hard disk has been brought up to speed, you may verify that it has been correctly installed and is ready for operation by booting the "ProDOS/SOS Software" or "Macintosh Software" disk included with the drive.

On the Apple //c and //e, select the Volume Manager option when the QC Hard Disk Utilities screen appears. On the Apple ///, the Volume Manager program will be immediately run on booting the "ProDOS/SOS Software" diskette. On the Macintosh, you must double-click on the Volume Manager icon to start up the program.

From the Volume Manager, request a "Catalog of Volumes" on your hard disk (on Macintosh, such a listing is immediately displayed when the Volume Manager is run). If you are able to get such a catalog, you have proven that the computer and hard disk are communicating. If not, you should go over the hardware installation instructions for your particular computer, and verify that they have been properly performed.

Note that the Apple //e software comes preconfigured to access the QC hard disk through a diskette controller card in Slot 6. If your system is not set up in this manner, you must first change this configuration as described in Chapter 4 before you will be able to verify the operation of your hard disk.

Operating Your Drive

Your QC hard disk drive has no operating controls except for its AC power switch. The red disk access light in the lower right hand corner of the unit illuminates whenever your computer transfers information to or from the disk.

After powering up the disk, all drive operations are controlled by the computer. Keeping track of files, saving, retrieving and deleting information are all functions controlled by your computer's operating system. You may learn more about your disk operating system by reading the manuals that came with your computer.

Those commands required to access the drive and manipulate files are described in the reference manuals for the particular application or language you are using.

Backing Up Your Hard Disk Files

The importance of making periodic backups cannot be overemphasized. Duplicate copies of important documents, data files, or the contents of your entire hard disk should be maintained in case the original copies are accidentally lost or destroyed.

The disk utility programs supplied with your computer may be used to make backup copies of the files on your QC hard disk. Detailed instructions for using these utilities may be found in their accompanying manuals.

Following is a list of programs which may be used for backup and file transfer purposes:

- The ProDOS Filer, on the Apple //c and //e.
- Backup //, supplied with Quark's Catalyst program selector for the Apple //c and //e.
- System Utilities on the Apple ///.
- Backup /// on the Apple ///.
- The Pascal language Filer's "Transfer" command.
- The Desktop Finder on Macintosh.

Of course, the QC hard disk drivers must be properly installed when attempting to use any of these utilities to access the hard disk.

Caring For Your Drive

Your QC hard disk drive is a delicate instrument, so handle it with care. Unlike your computer, the hard disk is a mechanical device with motors and moving parts. As such, it is much more delicate than the computer.

The hard disk has been completely aligned and tested at the factory, and with proper care and handling should provide troublefree operation. However, extensive damage or malfunction may result if the unit is accidentally bumped, jarred, dropped or handled roughly.

If Your Drive Doesn't Work

The disk drive and ventilation fan motors should start up when you turn on the AC power switch, indicating that power is available to the unit. If they don't, first make sure the unit is plugged in. Check that the power fuse located in the drive's power plug receptacle has not blown. If it has, replace it with one having the following rating:

250 Volt, 2.5 Amp, Fast Blow

Go over the hardware installation instructions for your particular computer, and verify that they have been properly performed. If you can get a "Catalog of Volumes" through the Volume Manager program, but cannot get your operational application programs to work with the QC hard disk, make sure that you have reconfigured your boot diskettes as explained in Chapter 4.

If your drive received excessive rough handling during shipping or unpacking, one of the connections inside of the hard disk cabinet may be loose. If you suspect this is the case, contact Quark Peripherals, Inc. for service information. Do not attempt to open the QC hard disk cabinet, as this will void your warranty.

Installation on the Apple IIc and IIe

Overview

Before you begin the installation of the software necessary for your computer to access the QC hard disk, you should understand how your Apple accesses diskette storage devices.

Most Apple //e users are already familiar with the concept of "slots", into which "peripheral cards" (performing various functions) may be installed. The Apple //e is typically set up with a Disk II diskette drive connected to a diskette controller card installed in **Slot 6**. This diskette drive is the one you use to boot your system.

On the Apple //c, the concept of slots and drives has been carried over from the //e, although the //c has no actual "physical" slots into which peripheral cards may be inserted. However, the internal and external diskette drives on the Apple //c may still be referenced as **"Slot 6, drive 1"** and **"Slot 6, drive 2"**, respectively.

Floppy diskettes may be accessed by your computer through either the "volume name" given to the diskette ("/FRED", "/WORD.JUGGLER", etc.) or through the physical "slot" and "drive" path that the diskette is connected to.

If you have used Apple's Filer program (used to copy or delete files, format diskettes, etc.), you probably already know that you must use diskette volume names in some instances (e.g. requesting a catalog of a diskette) and slot/drive numbers in others (e.g. formatting a diskette).

Your QC hard disk may be thought of as a regular floppy diskette drive, containing one or more separate user-defined areas of storage called "volumes". Just as you can access a floppy diskette in your system through its volume name or slot and drive number, you may access the volume(s) on your QC hard disk.

In order for your computer to access the hard disk, a set of software instructions called a "driver" is required. This driver contains the code necessary to talk to the hard disk, and also includes your definition of which slot/drive pairs may be used to access the volume(s) on the disk.

You can define up to four of these slot/drive "access paths" when you install or edit the driver software, enabling your computer to have access to four individual QC hard disk volumes at once. In this fashion, the drivers make the QC hard disk appear to your computer as up to four "pseudo" or "virtual" diskette drives.

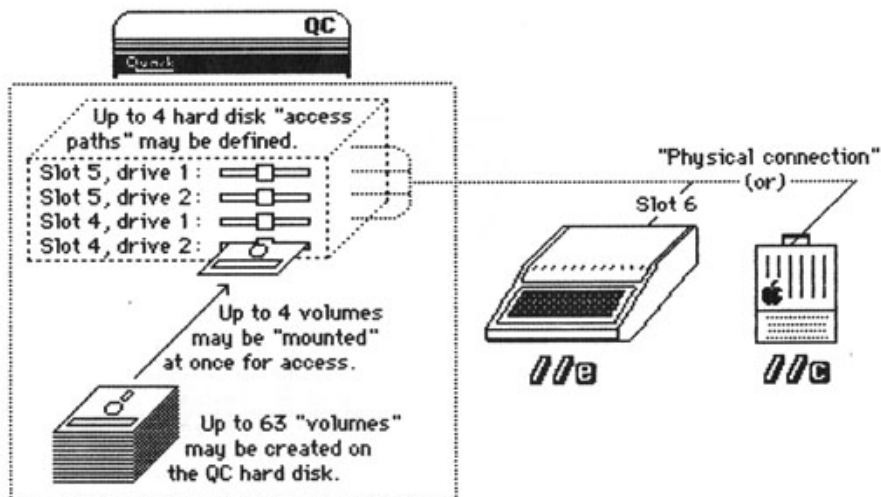

This figure depicts a typical system with a QC hard disk physically connected to the computer through Slot 6. In this example, four "access paths" have been defined in the hard disk driver, thus making the QC hard disk appear as four individual "virtual diskette drives" to the computer.

Note that the access path slot/drive assignment values shown above are only examples of what may be defined. These paths are independent of and should not be confused with the actual physical connection through which the QC hard disk is attached to your system.

The QC hard disk drivers must be loaded into your computer's memory before an application will be able to access the hard disk. These drivers are present on the "ProDOS/SOS Software" diskette you received with the QC hard disk. They may be loaded into memory through one of two methods:

- Booting the "ProDOS/SOS Software" diskette. The hard disk drivers are loaded into memory when the diskette is booted, and the QC Hard Disk Utilities program is automatically run. The "Start Application" option (see below) may then be selected to start up the program on your application boot diskette.
- Installing the hard disk drivers directly on your application's boot diskette. The hard disk drivers will then be automatically loaded into memory whenever you boot this application diskette.

The drivers present on the "ProDOS/SOS Software" diskette are preconfigured to enable access to a single hard disk volume through **Slot 5, drive 1**. (On the Apple //e, the drivers also expect the hard disk to be physically connected to an Apple Disk II or DuoDisk controller card in **Slot 6**.)

If you use the first method described above for loading the driver software (as it comes from the factory) into memory, your application will be restricted to this single access path. You may wish to modify the drivers on the "ProDOS/SOS Software" diskette itself to suit the needs of your application or reflect your unique hardware configuration.

The QC hard disk comes from the factory with a small demonstration volume automatically connected to the default access path (Slot 5, drive 1) when your computer is booted. If you installed the hard disk drivers on a ProDOS BASIC language diskette, for example, you could learn what files were on this volume by entering the standard BASIC command:

CAT,S5,D1

The remainder of the hard disk contains demonstration volumes for other Apple computers, and free space. You may reorganize the hard disk at any time, deleting these demo volumes and creating your own personal volumes.

Up to 63 different volumes may be defined on your hard disk. Each volume may be thought of as a separate "diskette", whose size is constrained only by the amount of storage remaining on the hard disk.

QC Hard Disk Utilities

The "ProDOS/SOS Software" diskette that came with your hard disk contains the QC Hard Disk Utilities program. By simply booting this diskette, the program is run enabling you to:

- Install the hard disk drivers on any bootable diskette, so the application program may access the QC hard disk.
- Change the hard disk access slot and drive number assignments for a driver already installed on a boot diskette.
- Run the Volume Manager program, discussed in detail in Chapter 6. This program enables you to create new or delete existing volumes on the hard disk, mount individual volumes for immediate access by your system, specify which volumes are to be automatically mounted when your system is booted, etc.
- Run the Filer program, which enables you to perform various file management functions with the hard disk.
- Start up an application from its boot diskette, with the QC hard disk drivers already loaded into memory.

The QC Hard Disk Utilities main menu is illustrated below:

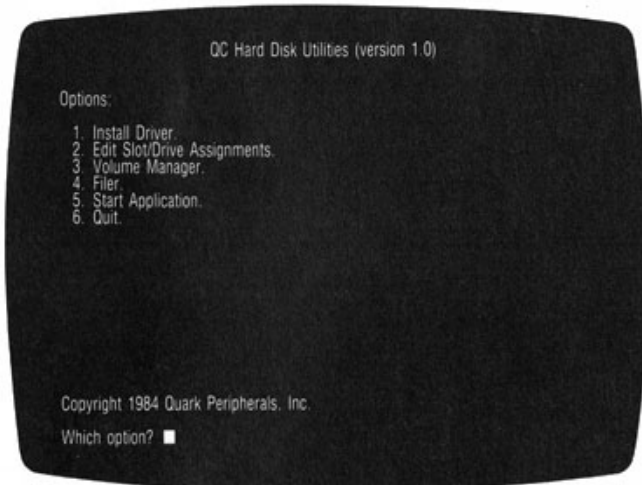

The menu options may be selected by entering their numbers or using the up or down arrow keys to move an inverse bar over the desired entry, and then pressing RETURN. The "Quit" option may also be selected by entering "Q".

1. Install Driver

The first entry on the QC Hard Disk Utilities main menu allows you to install the hard disk driver software on an application boot diskette.

An application boot diskette containing the hard disk drivers may be directly booted and have immediate access to hard disk volumes. Applications whose boot diskettes do not contain the hard disk drivers must go through a two-stage boot process before they may access the hard disk.

NOTE: On the Apple //e, the QC drivers are preconfigured to assume your hard disk is connected to a diskette controller card in **Slot 6**. If your system is not physically configured in this manner, you must perform the "Install Driver" option on the "ProDOS/SOS Software" diskette, and identify the slot to which your hard disk is connected.

As part of the driver installation process, you must specify which slot/drive pairs may be used to access the volumes on your hard disk. Up to four of these slot/drive pairs may be defined in the driver, enabling your computer to have access to four individual volumes at once.

When you select the "Install Driver" menu entry, you are first presented with a screen explaining the nature of the option. If you decide that you really don't want to install the hard disk drivers at this time, simply press ESCAPE.

If you are ready to proceed with the driver installation, put your application's boot diskette in the drive and press the space bar. The volume name of your application diskette will be displayed, and you are asked to confirm the driver installation for that diskette.

On the Apple //e, you are now requested to enter the number of the slot containing the Disk II card to which the hard disk is physically connected. Enter the appropriate value (most users will enter "6").

Next, you are presented with a screen showing the slot and drive number assignment(s) that may be used to access the volume(s) on your hard disk. This display will appear something like the following:

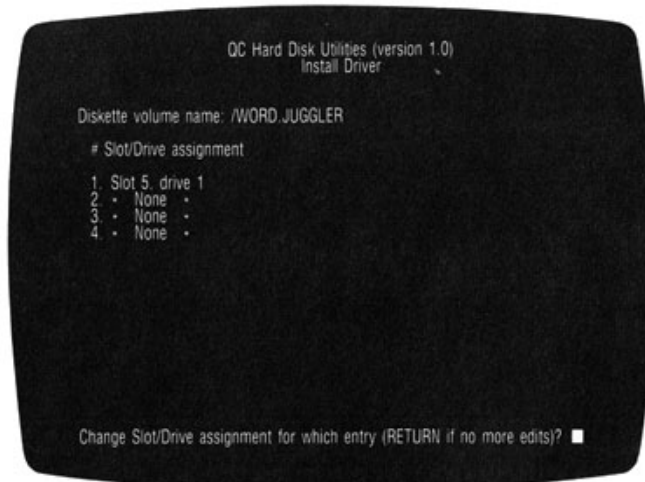

As illustrated above, the QC hard disk drivers come preconfigured to allow access to a single volume through **Slot 5, drive 1**. If this is suitable for your application, press RETURN to accept the default configuration.

If your application will require access to more than one hard disk volume at a time (or to a volume through a different slot/drive path than that shown above), you can easily modify the default configuration.

Use the up or down arrow keys to move an inverse bar over the entry to change, and then press RETURN. You may also select a particular entry for editing by simply entering its number (1 through 4).

When you select one of the four entries for modification, you are presented with a screen listing all access paths allowable for that entry. This list contains all possible slot/drive configurations, excluding those already in use.

The slot/drive pair assignments are simply a way for the hard disk drivers to access your QC volumes. They have no physical relation to any peripheral cards which may be installed in the slots. Thus, the assignments you select may be arbitrary. It is recommended, however, that you make assignments in the following order: **Slot 5/drive 1, Slot 5/drive 2, Slot 4/drive 1, Slot 4/drive 2.**

QC Hard Disk Utilities (version 1.0)
Install Driver

Diskette volume name: /WORD JUGGLER

Slot/Drive selection

1	.	None	.
2	Slot	1	drive 1
3	Slot	1	drive 2
4	Slot	2	drive 1
5	Slot	2	drive 2
6	Slot	4	drive 1
7	Slot	4	drive 2
8	Slot	5	drive 1
9	Slot	7	drive 1
10	Slot	7	drive 2

Which Slot/Drive for this position? █

Use the up or down arrow keys to move an inverse bar over the desired assignment, and then press RETURN. You may also select a particular entry by simply entering its number.

Note that the first entry (* None *) may be used to remove your selected slot/drive assignment from the list of possible hard disk access paths.

When you are satisfied with your edited slot/drive assignment configuration, press RETURN and the hard disk drivers will be written to your application boot diskette.

Finally, you are asked if you wish to install the same driver configuration on another boot diskette. If so, enter "YES" or simply press RETURN, and you will be given the opportunity to put another diskette in the drive. If you have no other diskettes on which to install this same driver configuration, enter "NO" or simply press ESCAPE.

2. Edit Slot/Drive Assignments

The second entry on the QC Hard Disk Utilities main menu will allow you to change the slot and drive number assignment(s) defined in the hard disk driver already installed on an application boot diskette. These assignments determine the paths by which your application may access the volumes on your hard disk.

NOTE: Since the QC hard disk drivers come preconfigured with a single slot and drive number assignment by which you may access the hard disk (**Slot 5, drive 1**), you may wish to add more assignments for the hard disk driver on the "ProDOS/SOS Software" diskette itself. This will permit the Volume Manager on that diskette to mount more than one volume at a time for access by your system.

When you select the "Edit Slot/Drive Assignments" menu entry, you are first presented with a screen explaining the nature of the option. If you decide that you really don't want to edit your hard disk drivers at this time, simply press ESCAPE.

If you are ready to proceed with editing the drivers, put your application's boot diskette in the drive and press the space bar. The volume name of your application diskette and the slot/drive assignments for accessing the hard disk are displayed, similar to the following:

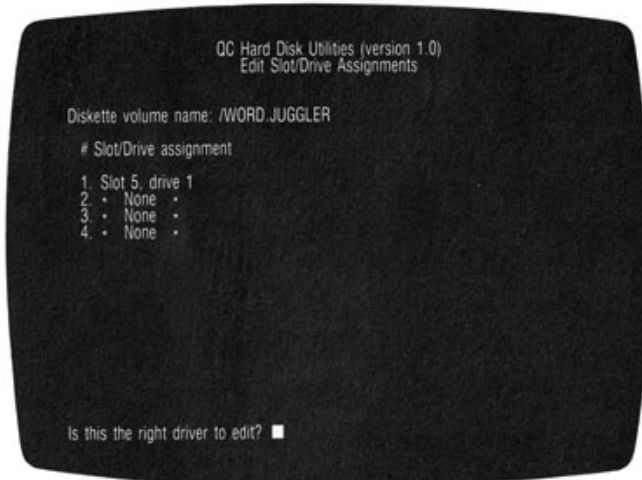

After confirming your application's hard disk drivers for editing, you are requested to specify which slot/drive assignment you wish to change. The editing of these assignments is performed in the same manner as described above for "Install Driver".

When you are satisfied with your new slot/drive assignment configuration, press RETURN and the updated hard disk drivers will be rewritten to your application boot diskette.

3. Volume Manager

Selecting this menu entry will run the Volume Manager program, discussed in more detail in Chapter 6. Briefly, this program will allow you to:

- Break up the hard disk into more than one volume, where each volume may be thought of as a separate "diskette".
- Mount individual volume(s) for immediate access by your system.
- Specify which volume(s) are to be automatically mounted for access by your system whenever it is booted.
- Perform various other housekeeping functions.

4. Filer

Selecting this menu entry will run the Apple Filer program, enabling you to perform various file management functions on your QC hard disk.

NOTE: This is a special version of the Apple Filer, modified to be compatible with the QC hard disk. You must use this version of the Filer to format all hard disk volumes created through the Volume Manager.

If you wish to return to the QC Hard Disk Utilities program on exiting from the Filer, first make sure that your "ProDOS/SOS Software" diskette is in the drive. Use the "Quit" option from the Filer's main menu, and enter the following when requested for the "Quit and Load Pathname":

QC.QUARK. (note the trailing period)

5. Start Application

This menu entry is useful when you wish to use your QC hard disk with an application boot diskette which does not have the hard disk drivers installed.

Simply insert your application boot diskette in the drive and press the space bar when requested. The ".SYSTEM" file (your application) on that diskette will then be loaded into your computer's memory and executed.

You may wish to make use of this option, for example, after using the Volume Manager to mount specific volumes for use by an application whose boot diskette has no room for the QC hard disk drivers.

Note that an application program which is started in this manner relies on the QC hard disk drivers from the "ProDOS/SOS Software" diskette. The slot and drive number assignments defined for that driver will determine the hard disk access path(s) your application may use.

6. Quit

The last entry on the QC Hard Disk Utilities main menu is used to exit the program. You are requested for the prefix and pathname for the next application to run.

Using Catalyst With the QC Hard Disk

You must use version 2.1 or greater of Quark's Catalyst program selector with the QC hard disk system. Adapting Catalyst to operate with the QC hard disk is fairly simple.

First, determine which slot/drive assignment path you want to use to access your "Catalyst device volume" (this hard disk volume will hold all programs installed by Catalyst).

If the preconfigured **Slot 5, drive 1** is not acceptable, (or if your QC hard disk is not physically connected through **Slot 6** on the Apple //e), you must perform the "Edit Slot/Drive Assignments" or "Install Driver" function (described above) on your "ProDOS/SOS Software" diskette.

Reboot the "ProDOS/SOS Software" diskette and select the Volume Manager option. Create a volume on the hard disk to use as your Catalyst device volume. Chapter 6 gives detailed instructions for creating hard disk volumes.

Next, set up your Catalyst device volume as an automatic mount on your chosen hard disk path assignment. Mount the volume for immediate access as well on this path assignment. You may now Quit from the Volume Manager.

Format your newly created volume with the Filer program, available through the QC Hard Disk Utilities main menu.

Finally, install the QC hard disk drivers on your Catalyst master and backup boot diskettes, using the procedure described above for "Install Driver". The slot/drive assignment path on which your newly created Catalyst device volume is mounted must be present in the driver configuration on your Catalyst boot diskette.

When you boot your system with your updated Catalyst diskette, you will be asked for your "Catalyst Drive Selection". Enter the number corresponding to the slot/drive assignment on which your newly created Catalyst device volume is mounted.

If you receive the message, "Drive not ready" after booting your updated Catalyst diskette, you probably didn't set up your Catalyst device volume as an automatic mount on your chosen hard disk path assignment. Use the Volume Manager to correct this problem.

Volume Manager Installation Under Catalyst

The "ProDOS/SOS Software" diskette must be used whenever you wish to install the hard disk drivers, edit their slot/drive assignments, or use the Volume Manager. If your system includes Quark's Catalyst program selector, you may install the Volume Manager as a separate Catalyst menu entry.

Of course, you must adapt Catalyst to operate with the QC hard disk before attempting this procedure. If you haven't already, perform the instructions listed above under "Using Catalyst With the QC Hard Disk".

To install the Volume Manager program as a separate Catalyst menu entry, perform the following procedure:

1. Select the Catalyst Editor from the Catalyst menu.
2. When the Catalyst Editor main menu comes up, select the "Install Program" option.
3. In the Program Manufacturers sub-menu, select "Miscellaneous manufacturers".
4. Insert your "ProDOS/SOS Software" diskette in the diskette drive as requested, and press the space bar. The Volume Manager will automatically be installed on your hard disk.
5. When installation is complete, Quit from the Catalyst Editor.

Installation on the Apple III and III +

Overview

Your QC hard disk may be thought of as a regular floppy diskette drive, with one or more very large, fast disks, each containing a separate area of storage called a volume. Just as you can access the diskette drives in your system by their device driver names (.D1, .D2, etc.), you may access the volume(s) on your QC hard disk.

In order for your computer to talk to the hard disk, a set of software instructions called a "driver" is required. This hard disk driver software must be loaded into memory either by a previous application, or by the inclusion of the drivers on an application's boot diskette in order for it to have access to the hard disk.

Four device drivers (.Q1, .Q2, .Q3, and .Q4) have been supplied with your QC hard disk to enable access by your Apple /// or ///+. The hard disk has been preconfigured to appear as a single small volume containing various demonstration programs and files, accessible through the device driver, ".Q1".

If you installed these hard disk drivers on a Business BASIC language diskette, for example, you could find out what files were on the demonstration volume by entering the standard BASIC command:

```
CAT .Q1
```

The remainder of the hard disk contains demonstration volumes for other Apple computers, and free space. You may reorganize the hard disk at any time, deleting the demo volumes and creating your own personal volumes.

Up to 63 different volumes may be defined on the disk. Each volume may be thought of as a separate "diskette", whose size is constrained only by the amount of remaining storage on the hard disk. Up to four of these volumes can be mounted (or connected to your system) at one time, each accessible by its unique device driver.

Installing the Device Drivers

The standard Apple System Utilities program that came with your computer may be used to install the QC hard disk drivers on any bootable diskette. To do this, first boot the System Utilities program, and then perform the following procedure:

1. From the System Utilities main menu, enter "S" for the System Configuration Program option.
2. Type "R" to Read a Driver.
3. Insert the boot diskette onto which you wish to install the QC hard disk drivers in the internal drive. Press RETURN to accept ".D1/SOS.DRIVER" as the next driver file to load. A listing of the drivers on your boot diskette will appear on the screen.
4. Replace your application boot diskette in the internal drive with the "ProDOS/SOS Software" diskette. Enter ".D1/QC.SOS.DRIVER" as the next driver file to load. The QC hard disk drivers will appear on the screen. Press ESCAPE.
5. If you booted the System Utilities diskette directly (instead of selecting it through a Catalyst menu entry) before starting this procedure, reinsert the System Utilities diskette in the internal drive.
6. Although not required, you may wish to Edit the QC hard disk (or any other) drivers at this time. To do so, enter an "E". Your System Utilities manual will give you procedures for selectively activating or deactivating the drivers, or changing their names. Press ESCAPE when you finish editing the drivers.
7. Type "G" to Generate a New System. When you are prompted to enter the new driver file name, insert your application boot diskette onto which you wish to install the QC hard disk drivers in the internal drive (if it isn't already). Enter ".D1/SOS.DRIVER" as the driver file to generate.
8. Enter "Y" to indicate that you wish to delete the existing SOS.DRIVER file. If the message "File is Write Protected" appears, enter "Y" again to indicate that you wish to delete the file anyway. The message "System Generated" should appear on the screen. If a message like "Driver File Too Large" or "No Room On Volume" appears instead, you will have to delete another driver before you can generate a new SOS.DRIVER file on your boot diskette.

To verify that your computer can communicate with the QC hard disk, reboot your system with the newly configured boot diskette. Use whatever command is appropriate in your application to display the directory or otherwise access the volume connected to the .Q1 hard disk driver.

The Volume Manager

The "ProDOS/SOS Software" diskette that came with your hard disk contains the Volume Manager program, discussed in more detail in Chapter 6. By simply booting this diskette, the program will enable you to:

- Break up the hard disk into more than one volume, where each volume may be thought of as a separate "diskette".
- Mount individual volume(s) for access by your system.
- Specify the volume(s) to be automatically mounted for access by your system whenever it is booted.

Using Catalyst With the QC Hard Disk

You must use version 2.1 or greater of Quark's Catalyst program selector with the QC hard disk system. Adapting Catalyst to operate with the QC hard disk is fairly simple.

Begin by setting up a volume on the hard disk to use as your "Catalyst device". This is the volume on which all programs installed by Catalyst will reside. Chapter 6 gives detailed instructions for creating volumes on your hard disk.

Next, determine which hard disk device driver (.Q1, .Q2, .Q3, .Q4) you want to use to access your Catalyst device. Use the Volume Manager to set up your Catalyst device volume as an automatic mount for your selected driver. Mount the volume for immediate access as well on this driver.

Use the System Utilities program to format your newly created Catalyst device hard disk volume. Remember that the hard disk drivers must be present on the System Utilities boot diskette (or have already been loaded into memory) in order for the program to access the hard disk.

Finally, install the QC hard disk drivers on your Catalyst master and backup boot diskettes, using the procedure described above in "Installing the Device Drivers". In

step 6 of that procedure, you must Edit the Catalyst Device Configuration Block (DCB) to recognize the hard disk driver you have selected to access your Catalyst device.

Change the first six bytes of the Catalyst DCB to reflect your selected hard disk driver as follows:

```
00 00 F1 AA 23 00 (for .Q1)
00 01 F1 AA 23 00 (for .Q2)
00 02 F1 AA 23 00 (for .Q3)
00 03 F1 AA 23 00 (for .Q4)
```

Volume Manager Installation Under Catalyst

The "ProDOS/SOS Software" diskette must be used whenever you wish to use the Volume Manager. If your system includes Quark's Catalyst program selector, you may install the Volume Manager as a separate Catalyst menu entry. To do this, perform the following procedure:

1. Select the Catalyst Editor from the Catalyst menu.
2. When the Catalyst Editor main menu comes up, select the "Move interpreter to hard disk" option.
3. Insert your "ProDOS/SOS Software" diskette in the internal diskette drive as requested, and press the space bar. Enter "CATALYST/QCMANAGER" as the hard disk pathname. The Volume Manager will be placed on your hard disk.
4. Type "E" to Edit the Catalyst menu.
5. Move the inverse bar to the point on your menu just after where you wish to add the Volume Manager menu entry. Type "A" to Add a program entry.
6. Enter "QC Volume Manager" for the menu Display name.
7. Enter "CATALYST/QCMANAGER" for the Interpreter path.
8. Press RETURN for Extra drivers, Character set path, Screen, Keyboard path, and Initial prefix.
9. Enter "0" (zero) for Max files allowed open.
10. Press RETURN for Program path.
11. If all of the above has been entered correctly, press RETURN when asked "Is all this correct?". Otherwise, enter "NO", and fix the incorrect entry.
12. Press ESCAPE to return to the Catalyst Editor main menu. Enter "U" to Update the INTERPS file.
13. Enter "Y" when asked if the Minimum interpreter load address should be recalculated. Follow the instructions supplied on the screen.
14. Enter "Q" to Quit from the Catalyst Editor.

Installation on the Macintosh

Overview

Your QC hard disk may be thought of as a regular floppy disk drive, with one or more very large, fast disks, each containing a separate area of storage called a volume. Just as you can access the disk drives in your system through the manipulation of their disk icons on the desktop, you may access the volume(s) on your QC hard disk.

In order for your computer to communicate with the hard disk, a set of software instructions called a "driver" is required. This hard disk driver software must be loaded into memory before an application is run in order for it to have access to the hard disk.

The hard disk has been preconfigured to appear as a single small volume containing various demonstration programs and files. This volume may be accessed through the desktop Finder in the same manner that programs and files on a floppy disk are accessed.

When you start up your system with the "Macintosh Software" disk for example, the demonstration volume's icon (representing a QC hard disk) automatically appears on the desktop. By double-clicking on this icon, a window will appear showing the programs and files present on the volume.

The remainder of the hard disk contains demonstration volumes for other Apple computers, and free space. You may reorganize the hard disk at any time, deleting the demo volumes and creating your own personal volumes.

Up to 63 different volumes may be defined on the disk. Each volume may be thought of as a separate "diskette", whose size is constrained only by the amount of remaining storage on the hard disk.

Any number of these volumes (limited only by the amount of memory in your system) can be mounted (or connected for access) at one time, each accessible by its unique QC hard disk icon.

Installing the Device Drivers

The "Macintosh Software" disk supplied with your QC hard disk system contains the QC hard disk drivers. When you start up or "boot" the Macintosh with this disk, the hard disk drivers are loaded into memory, enabling subsequent applications to have access to the QC hard disk.

Alternatively, you may copy the program named QC STARTUP from the "Macintosh Software" disk to an application disk, for example, MacPaint. When you execute QC STARTUP, the hard disk drivers are loaded into memory, and MacPaint or any subsequent application may then access the hard disk.

To further simplify the loading of the QC drivers, you may make QC STARTUP the startup application on any floppy disk. This is performed through the "Set Startup" option in the Finder's "Special" menu. QC STARTUP will then be run automatically when you boot the disk it resides on.

The Volume Manager

The "Macintosh Software" disk also contains the Volume Manager program, discussed in more detail in Chapter 6. By simply booting this disk and double-clicking on the Volume Manager icon, the program is run, enabling you to:

- Break up the hard disk into more than one volume, where each volume may be thought of as a separate "diskette".
- Mount individual volume(s) for access by your system.
- Specify the volume(s) to be automatically mounted for access by your system whenever it is booted.

You may wish to copy the Volume Manager program to the same boot disks on which you have copied QC STARTUP (as explained above). The Volume Manager may also be copied to any of your hard disk volumes for convenience.

CHAPTER FIVE

OPERATING ENVIRONMENT

Overview

Your QC hard disk drive may readily be used under Apple's Professional Disk Operating System (ProDOS) on the Apple //c and Apple //e computers, under the Sophisticated Operating System (SOS) on the Apple ///, and with the Macintosh system as well. Of course, the appropriate driver software must properly be installed on your system before attempting to communicate with the hard disk.

After installing your QC hard disk and its associated driver software, normal ProDOS, SOS, or Macintosh commands may be issued to perform the same type of operations possible with conventional floppy diskettes.

These operations include changing the name assigned to a volume by the operating system (not necessarily the same as the name used by the Volume Manager, see Chapter 6), obtaining catalog listings, saving and deleting files, etc.

The disk utility programs supplied with your computer (including the ProDOS Filer, SOS's System Utilities, etc.) may also be used with your QC disk drive.

Using the QC Hard Disk Under ProDOS

The individual volume(s) on your QC hard disk are mounted or made available to your system through a slot and drive number, just like floppy diskettes. These volumes may be accessed by their slot and drive assignment, or by their operating system volume name.

The Filer program supplied through the QC Hard Disk Utilities program on the "ProDOS/SOS Software" diskette contains QC compatible disk formatting code. This version of the Filer **must** be used to format a newly created volume on the hard disk. The name by which ProDOS refers to the volume is first requested when the volume is formatted.

All commands available in the Filer program may be used with your QC hard disk, including:

- Obtaining catalog listings of your volumes.
- Copying selected files to or from hard disk volumes.
- Deleting files on your hard disk volumes.
- Comparing files.
- Changing the write protection status of files on a volume.
- Renaming files.
- Making subdirectories on your volumes.
- Using the Volume Copy command to exchange the contents of equivalent sized volumes, including a floppy diskette and a hard disk floppy equivalent volume (280 blocks in size).
- Listing the volumes currently connected to your system.
- Changing a volume's operating system volume name.
- Detecting bad blocks on a volume.
- Determining the block allocation for a volume.
- Comparing two volumes of the same size.

Commands available through BASIC for manipulating diskette contents may also be used with your QC hard disk. Files on the hard disk may be loaded, stored, deleted, renamed, locked, unlocked, etc. just as with floppy diskettes.

Using the QC Hard Disk Under SOS

The individual volume(s) on your QC hard disk are mounted or made available to your system through a hard disk driver, just like floppy diskettes. These volumes may be accessed by their driver name, or by their operating system volume name.

All commands available through the standard Apple System Utilities program supplied with your computer may be used with your QC hard disk, including:

- Obtaining catalog listings of your volumes.
- Copying selected files to or from hard disk volumes.
- Deleting files on your hard disk volumes.
- Changing the write protection status of files on a volume.
- Renaming files.
- Making subdirectories on your volumes.
- Using the Volume Copy command to exchange the contents of equivalent sized volumes, including a floppy

diskette and a hard disk floppy equivalent volume (280 blocks in size).

- Listing the volumes currently connected to your system.
- Changing a volume's operating system volume name.

Commands available through Business BASIC or Pascal for manipulating diskette contents may also be used with your QC hard disk. Files on the hard disk may be loaded, stored, deleted, renamed, locked, unlocked, etc. just as with floppy diskettes.

Using the QC Hard Disk With Macintosh

The individual volume(s) on your QC hard disk are mounted or made available to your system through the Volume Manager program. Once mounted, these volumes may be accessed just like floppy disks.

All functions available through the desktop Finder may be used with your QC hard disk volume files, including:

- Determining the contents of your volumes.
- Moving selected files between floppy or hard disk volumes.
- Moving files from your hard disk volumes to the trash can.
- Changing the write protection status of files on a volume.
- Renaming files.
- Making folder subdirectories on your volumes.
- Changing a volume's operating system volume name.

Commands available through standard Macintosh applications and languages for accessing floppy disk contents may also be used with your QC hard disk.

Performance

Your QC hard disk drive may completely eliminate the floppy shuffling behavior which is often required on a Macintosh system having only one or two floppy disk drives. Many different applications may be moved to the hard disk, and may be accessed after initially booting only one floppy.

All commands available in the Filer program may be used with your QC hard disk, including:

- Obtaining catalog listings of your volumes.
- Copying selected files to or from hard disk volumes.
- Deleting files on your hard disk volumes.
- Comparing files.
- Changing the write protection status of files on a volume.
- Renaming files.
- Making subdirectories on your volumes.
- Using the Volume Copy command to exchange the contents of equivalent sized volumes, including a floppy diskette and a hard disk floppy equivalent volume (280 blocks in size).
- Listing the volumes currently connected to your system.
- Changing a volume's operating system volume name.
- Detecting bad blocks on a volume.
- Determining the block allocation for a volume.
- Comparing two volumes of the same size.

Commands available through BASIC for manipulating diskette contents may also be used with your QC hard disk. Files on the hard disk may be loaded, stored, deleted, renamed, locked, unlocked, etc. just as with floppy diskettes.

Using the QC Hard Disk Under SOS

The individual volume(s) on your QC hard disk are mounted or made available to your system through a hard disk driver, just like floppy diskettes. These volumes may be accessed by their driver name, or by their operating system volume name.

All commands available through the standard Apple System Utilities program supplied with your computer may be used with your QC hard disk, including:

- Obtaining catalog listings of your volumes.
- Copying selected files to or from hard disk volumes.
- Deleting files on your hard disk volumes.
- Changing the write protection status of files on a volume.
- Renaming files.
- Making subdirectories on your volumes.
- Using the Volume Copy command to exchange the contents of equivalent sized volumes, including a floppy

diskette and a hard disk floppy equivalent volume (280 blocks in size).

- Listing the volumes currently connected to your system.
- Changing a volume's operating system volume name.

Commands available through Business BASIC or Pascal for manipulating diskette contents may also be used with your QC hard disk. Files on the hard disk may be loaded, stored, deleted, renamed, locked, unlocked, etc. just as with floppy diskettes.

Using the QC Hard Disk With Macintosh

The individual volume(s) on your QC hard disk are mounted or made available to your system through the Volume Manager program. Once mounted, these volumes may be accessed just like floppy disks.

All functions available through the desktop Finder may be used with your QC hard disk volume files, including:

- Determining the contents of your volumes.
- Moving selected files between floppy or hard disk volumes.
- Moving files from your hard disk volumes to the trash can.
- Changing the write protection status of files on a volume.
- Renaming files.
- Making folder subdirectories on your volumes.
- Changing a volume's operating system volume name.

Commands available through standard Macintosh applications and languages for accessing floppy disk contents may also be used with your QC hard disk.

Performance

Your QC hard disk drive may completely eliminate the floppy shuffling behavior which is often required on a Macintosh system having only one or two floppy disk drives. Many different applications may be moved to the hard disk, and may be accessed after initially booting only one floppy.

You may wonder why the speed of your Macintosh system is not substantially increased in some cases. The desktop Finder simply has more work to do in keeping track of all the files when large hard disk volumes containing a significant number of files are mounted.

When system response seems slow, you can verify that the computer is hard at work (and not being slowed down by the hard disk) by observing that the disk access light on the QC hard disk is extinguished much of the time.

You may be able to improve the response time of the Finder by unmounting any volumes which are not absolutely necessary.

Access to the hard disk is much faster than with standard floppy disks. Programs that perform a great deal of disk reading and writing will execute much faster when utilizing the QC hard disk.

Overview

Your QC hard disk may be thought of as a regular floppy diskette drive, with one or more very large, fast disks, each containing a separate area of storage called a volume.

The hard disk is preconfigured to appear to your system as a single small volume containing various demonstration programs and files. The remainder of the hard disk contains demo volumes for other Apple computers, and free space. You may reorganize the hard disk at any time, deleting the demo volumes and creating your own personal volumes.

Up to 63 different volumes may be defined on the disk. Each volume may be thought of as a separate "diskette", whose size is constrained only by the amount of remaining storage on the hard disk. A number of these volumes can be mounted (or connected for access by your system) at one time.

The Volume Manager is used to manipulate the volumes on your QC hard disk. Specifically, this program will allow you to:

- Create new volumes on the hard disk.
- Obtain a display showing all volumes currently defined.
- Specify which volume(s) are to be mounted for immediate access by your system.
- Specify which volume(s) are to be automatically mounted for access by your system when it is booted.
- Delete volumes which are no longer needed.
- Change the characteristics associated with a given volume, including the volume's name, volume type and access restrictions (discussed below).
- Change the system master password which grants full access to any volume (discussed below).
- Retract the heads from the surface of the hard disk to allow the unit to be safely shipped. Whenever the Volume Manager is run, this is automatically performed.

The procedures for starting up and operating the Volume Manager will differ slightly for different computers. You need be concerned only with the section that pertains to your particular computer. But first, there are a few concepts concerning volumes that you should understand.

Access Restrictions

Access to your volumes may be completely unrestricted, or may be limited through the use of passwords. You may wish for certain users to be able to read but not alter the information on a certain volume, for example, and allow others to both read and write the volume.

The QC hard disk system utilizes three levels of access, plus an overriding system password (initially, "MASTER") which grants full access to a volume. The three levels are:

- PUBLIC access, granted when no password is supplied for a volume.
- GROUP access, granted when the GROUP password is supplied for a restricted volume.
- PRIVATE access, granted when the PRIVATE password is supplied for a restricted volume.

These access rights are brought into use by the Volume Manager when you edit current or automatic mounts, delete a volume, or edit a volume's characteristics.

Access rights are usually structured in a manner such that the lowest level (PUBLIC) has fewer rights than the highest (PRIVATE). The accesses granted to a particular user depend on which password (if any) is used when referencing the volume in the Volume Manager.

When creating a volume, you may specify "No Access", "Read Only" or "Read/Write" (full) access for the PUBLIC and GROUP levels. If PUBLIC access is Read/Write and both GROUP and PRIVATE have No Access, the volume is considered to be unrestricted. Full access is granted in the Volume Manager when you reference the volume, and to anyone wishing to access the volume after it is mounted.

Read/Write access is given to the PRIVATE level if a PRIVATE password is supplied. If not, this level gets No Access.

The system master password may be used to gain access to a restricted volume whose password you have forgotten. It is strongly suggested that the initial master password be changed if you desire to restrict access to any of your volumes. Do not forget your system master password. Write it down and hide it in a safe place.

The ability to delete a volume ("Delete" access) in the Volume Manager is automatically granted to the highest level having any access rights at all. An example of passwording follows:

```
PUBLIC access   = None
GROUP access   = Read Only
PRIVATE access = Read/Write & Delete
```

In this example, a password must be used when mounting the volume (since PUBLIC access is None). If the GROUP password is given when mounting the volume, the volume's data may be read but not changed. The PRIVATE password must be given when attempting to delete the volume, edit its characteristics or mount it for both Read and Write access. The system master password has full access to the volume.

A password may consist of up to 15 printable characters, may not start with a blank, and must be unique. No distinction is made between upper and lowercase letters, so the password "FRED" is equivalent to "Fred".

Volume Names

When you create a new volume in the Volume Manager, you are asked to supply a "volume name". This name is used only in the Volume Manager to refer to a specific area of storage. It appears in the Volume Manager's "Catalog of Volumes" for your hard disk, and is used when mounting, unmounting, deleting or editing the characteristics of a volume.

Volume names may consist of up to 15 characters, must be unique, and may not start with a blank. Any printable characters may be used in a volume name. No distinction is made between upper and lowercase letters, so the volume name "FRED" is equivalent to "Fred".

This name should not be confused with the name by which your operating system refers to the volume. The operating system volume name is first given to a volume when it is formatted or initialized (erased).

For example, suppose you create a volume with the name, "FRED". You would use this name in the Volume Manager when mounting it for access by your system. When you first format the volume, you might give the name, "DATA", when asked for the volume's operating system name.

Assume for the moment that you created this volume on the Apple //c. Later on, if you wished to execute the BASIC program named "GEORGE", saved in the root level of this volume, you would type: "RUN /DATA/GEORGE"

If your volume was created on the Macintosh, and you mounted "FRED" for access by your system, you would see the QC hard disk icon with the volume name, "DATA" on the desktop.

Volume Type

The volume type is simply an indicator of the type of files (and consequently, the operating system which will access those files) residing on a volume. This indicator appears in the Volume Manager simply for your edification when obtaining catalog listings, editing current or automatic mounts, deleting volumes, or editing volume characteristics.

The following volume types are available:

- ProDOS/SOS
- Pascal //
- Macintosh
- Other

Specifying "Other" for the volume type allows you to enter up to 10 printable characters to describe your volume type. This will allow you to identify the volume with your own remarks.

When creating a new volume, the volume type specified also determines the how the QC hard disk system may optimally access your volume. If you create a Macintosh volume, be sure to specify "Macintosh" as the volume type, as these volumes are specially configured to improve their performance on that system.

Note that you can mount any type of volume on any system, although you may not be able to read that volume's information. Be especially careful when mounting volumes on the Macintosh. The Mac will ask if you want to initialize (erase) non-Macintosh volumes when they are mounted!

Apple IIc, IIe and III Volume Manager

On the Apple //c and //e computers, up to four slot/drive pairs are available to mount volumes for access by your system. The slots referenced may not have a disk controller card inserted into them. This avoids conflicts between the QC hard disk and other drives in your system.

On the Apple ///, up to four drivers are available to mount volumes for access by your system. The standard Apple System Utilities program may be used to selectively activate or deactivate these drivers, or change their names.

To start up the Volume Manager program, boot the diskette labeled "ProDOS/SOS Software". On the Apple //c and //e, you must select the Volume Manager entry from the QC Hard Disk Utilities menu. The Volume Manager may also be installed and immediately accessed by Quark's Catalyst program selector (see the "Software Installation" section).

Once you have started up the Volume Manager program, you are presented with a screen displaying its menu of options, as illustrated below:

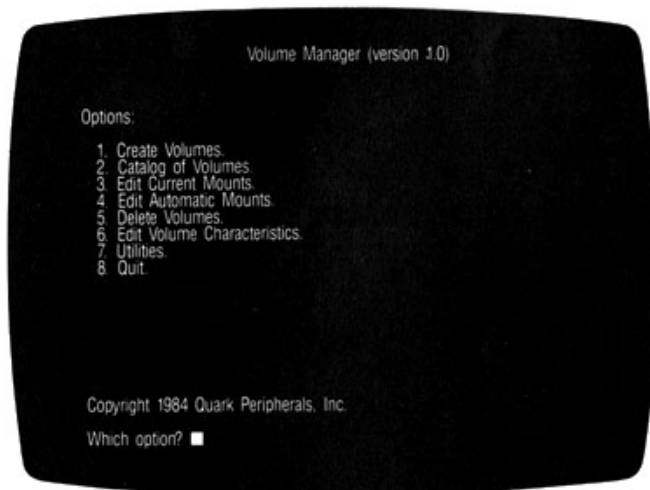

The menu options may be selected by entering their numbers or using the up or down arrow keys to move an inverse bar over the desired entry, and then pressing RETURN. The "Quit" option may also be selected by entering "Q".

1. Create Volumes

The first entry on the Volume Manager main menu allows new volumes to be created. The QC hard disk system will allow up to 63 different volumes to be created.

When creating a new volume, four things must be taken into consideration:

- Volume name
- Volume type
- Size
- Access restrictions

When you select the "Create Volumes" option, you are presented with a display listing the names of all volumes currently defined on the hard disk. The display will request you to enter the name of the volume you wish to define. An example of this display follows:

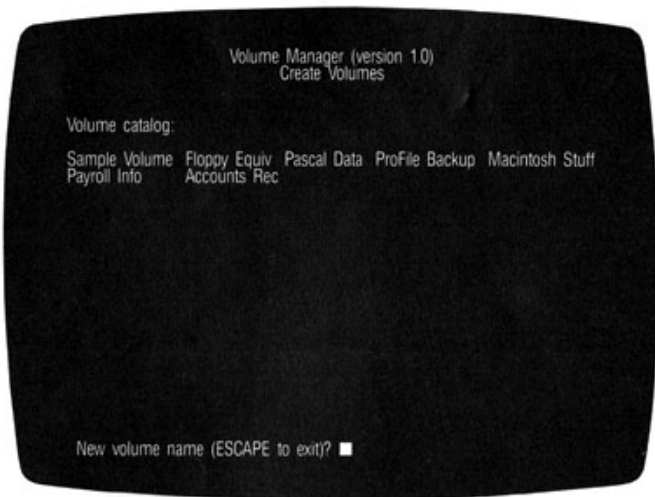

Of course, the name you select for your volume must be different than the names of the volumes already created on your hard disk. Enter your volume name, and press RETURN.

Next you are presented with the following screen, requesting you to enter your volume type:

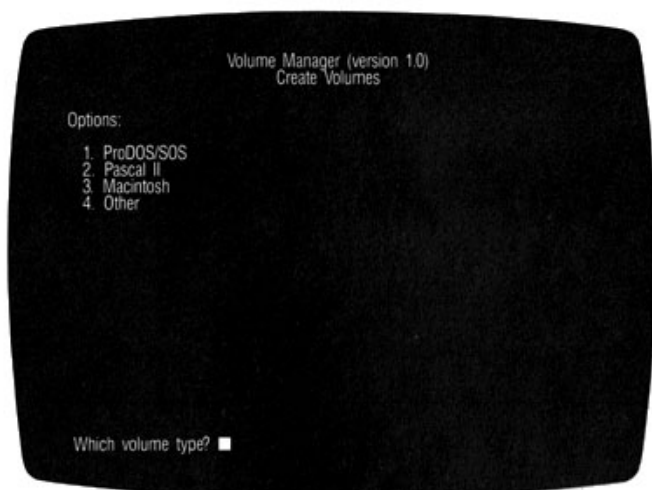

Enter the number corresponding to your desired volume type, and press RETURN. If you select number 4, you will be prompted to enter your own 10-character volume type.

Next, you will be asked to enter the size of your volume. Volume size is specified in units of "blocks", where one block is equivalent to 512 bytes or characters of storage.

The size you specify will depend on what you intend to use the volume for and how much room is left on your hard disk. Volumes must be at least 64 blocks in size. A floppy diskette on the Apple //c, //e, and /// computers will hold 280 blocks of storage. On the Macintosh, a single floppy can hold up to 800 blocks.

One megabyte is approximately 2000 blocks. If you wish to configure your hard disk as one gigantic volume, delete all remaining volumes on the disk (first, make sure that you really don't need them), then use the Catalog of Volumes command to find out how much room is available on the disk.

Finally, you are asked what access restrictions should be placed on your volume. If you want anyone to be able to have full access to your volume, enter "YES" or simply press RETURN when asked "OK to allow unrestricted access on this volume?".

If you enter a negative response to this question, you will be asked to enter the accesses to be granted for PUBLIC and GROUP access, and for their corresponding passwords if you

allow any access at these levels. You are then asked for the PRIVATE password. If you don't enter a PRIVATE password, no PRIVATE access will be granted. Otherwise Read/Write access will be used for the PRIVATE access rights.

On completing a new volume definition, a screen showing the volume's attributes is displayed, similar to the following. You are asked to confirm the volume creation.

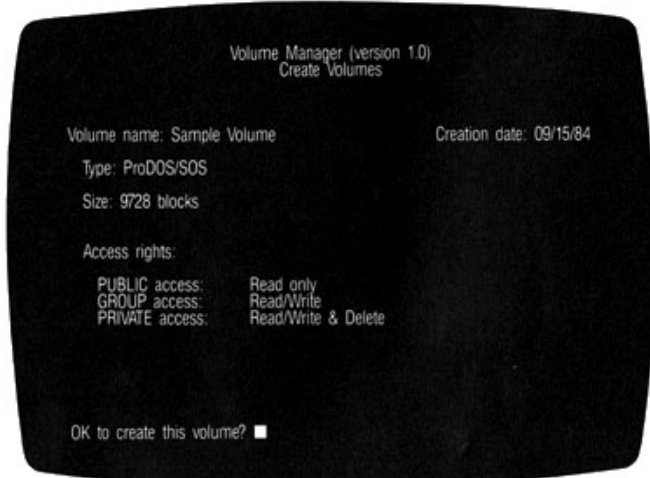

You may then repeat the entire process by entering the name of another volume to create, or press ESCAPE to exit the "Create Volumes" menu entry.

On the Apple //c and //e, you **must** format a newly created volume with the Filer program supplied through the QC Hard Disk Utilities program on the "ProDOS/SOS Software" diskette. On the Apple ///, the standard Apple System Utilities program may be used to format the volume.

2. Catalog of Volumes

The second entry on the Volume Manager main menu allows a catalog display to be obtained of all volumes on your QC hard disk. The volume name, volume type and size in blocks (all described above) are shown along with the date each volume was created, similar to the following:

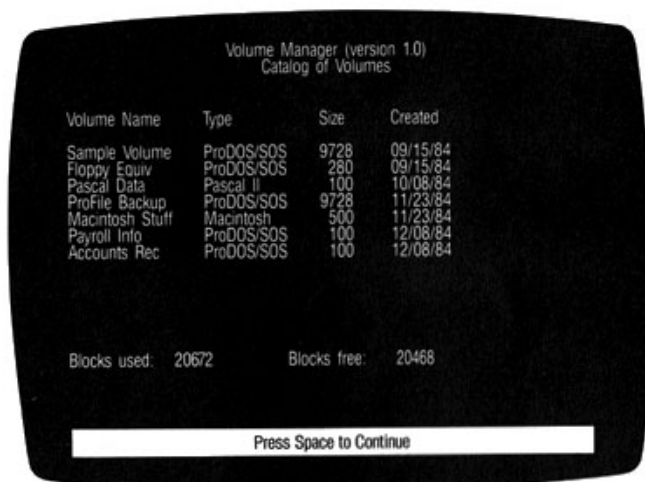

If your hard disk has more volumes than can be displayed on one screen, you may press the space bar to see the remaining volumes. At the end of the list, the total number of blocks consumed by all of your volumes is shown, along with the number of free blocks remaining on the disk.

If your hard disk contains any damaged volumes, a message to that effect will be displayed in the "Catalog of Volumes".

3. Edit Current Mounts

The third entry on the Volume Manager main menu allows you to selectively mount (or unmount) volumes for immediate access by your system. The term, "mount" refers to the association of a volume with a particular slot and drive number (on the Apple //c and //e computers) or particular driver (on the Apple ///).

On selecting this menu entry, you are presented with a screen listing the slot/drive pairs or driver names in your system which are available for use by the QC hard disk system. If a volume is mounted on a particular slot/drive pair or driver, the name, volume type, and current access privileges of the volume are displayed. You are then prompted for the slot/drive pair or driver for which you wish to change mounts.

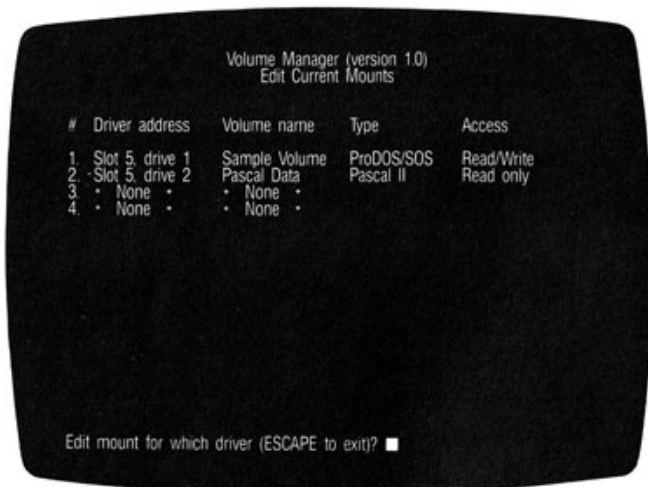

Editing Current Mounts (Apple //c and //e)

Note that there are two slot/drive pairs available for mounting volumes in the above example. To change this configuration, see Chapter 4 for how to Edit Slot/Drive Assignments.

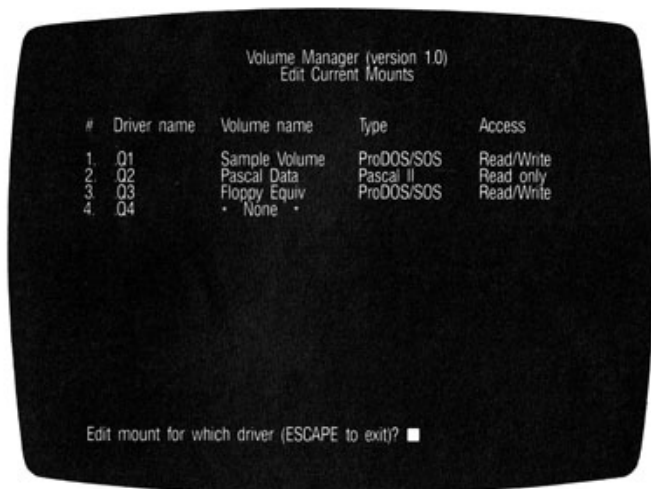

Editing Current Mounts (Apple ///)

On selecting the slot/drive pair or driver to edit, a list of current volume names is presented. You are then asked which volume should replace the one currently mounted (if any) on the slot/drive pair or driver in question.

Pressing RETURN in response to this question will unmount the volume currently associated with the slot/drive pair or driver. If a volume name is entered instead, it will be mounted on the selected slot/drive pair or driver.

After specifying the name of a volume to mount, you are asked if it should be mounted with Read/Write access. If you plan to both read and write information on the volume, you should enter, "YES", or simply press RETURN. If you enter a negative response, the volume will be mounted with Read only access.

If the volume has access restrictions, you will be asked for the password necessary to grant the access you requested (Read Only or Read/Write). If an incorrect password is supplied, the volume is not mounted.

Note that a volume may not be mounted on more than one slot/drive pair or driver. If you wish to move a volume to a different slot/drive pair or driver, first unmount the volume, and then mount it on your new selection.

4. Edit Automatic Mounts

The fourth entry on the Volume Manager main menu allows you to specify those volumes to be automatically mounted when your system is booted. The term, "mount" refers to the association of a volume with a particular slot and drive number (on the Apple //c and //e computers) or particular driver (on the Apple ///).

The procedure for changing your automatic mounts is the same as that described above for editing current mounts. Note that changing automatic mounts only affects those volumes to be attached at system boot. Your current mounts are unaffected when you edit automatic mounts.

5. Delete Volumes

The fifth entry on the Volume Manager main menu allows you to selectively remove previously defined volumes from the QC hard disk system. All storage associated with a volume is released when that volume is deleted. The freed storage is then available for use by any subsequent volume definitions.

On selecting this menu entry, you are presented with a screen listing the current volumes defined on the hard disk. You are then prompted for the name of the volume to delete. If a valid volume name is entered, a screen showing that volume's attributes is displayed, and you are asked to confirm the deletion:

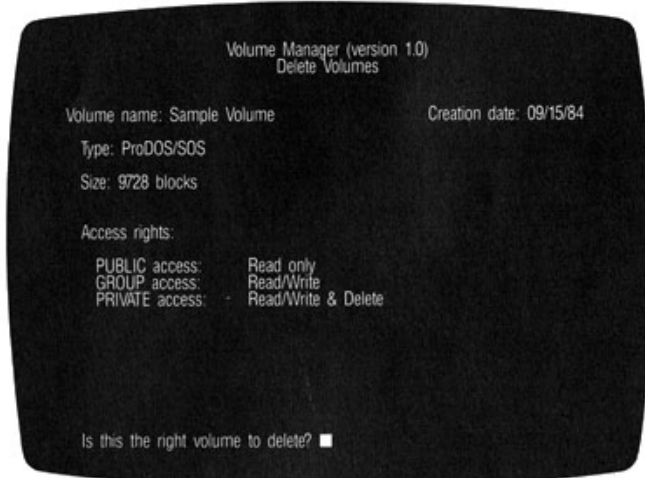

If you respond to this question in the affirmative, the volume is deleted and its storage is released into the free disk space. If the volume has access restrictions (described above), you will first be asked for the password which will grant "Delete" access before the volume is deleted.

Note that you may not delete a volume if it is currently mounted. If you attempt to delete a volume which has been set up as an automatic mount (for any system), you will receive a warning message and be given the opportunity to abort the volume deletion.

6. Edit Volume Characteristics

The sixth entry on the Volume Manager main menu allows you to selectively change the attributes associated with a given volume. The volume name, volume type and access restrictions may be changed in this manner.

To change the size of a volume, you must create a new volume with your desired size, copy all information from the old volume to the new one, and then delete the old volume. Finally, you may wish to change the name of the new volume to that of the old.

On selecting the "Edit Volume Characteristics" menu entry, you are presented with a screen listing the current volumes defined on the hard disk. You are then prompted for the name of the volume whose characteristics you wish to change.

If a valid volume name is supplied, a screen showing that volume's attributes is displayed, and you are asked to confirm the edit selection. If the volume has access restrictions (described above) you will first be prompted to enter the password which will grant "Delete" access. When you confirm your edit selection, you are presented with a display requesting which characteristic you wish to change:

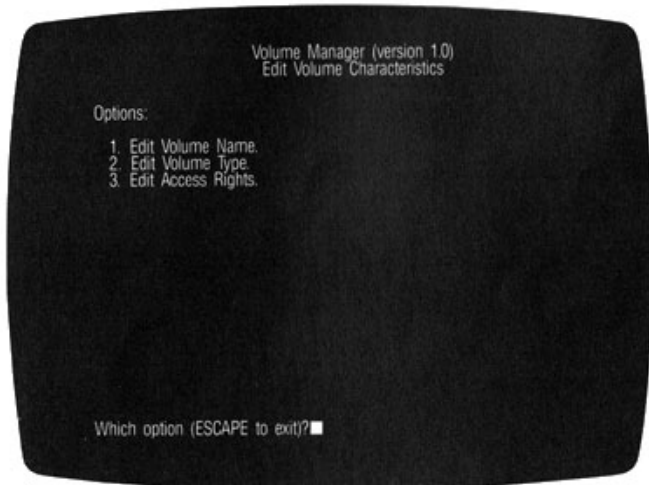

- The "Edit Volume Name" option will display all volumes currently defined on your hard disk, and prompt you for the new volume name.
- The "Edit Volume Type" option will display a list of possible volume types, and prompt you for the new type.
- The "Edit Access Rights" option will prompt you for the access restrictions to place on the volume, as described above in "Create Volumes".

After entering the new information, you are returned to the display above. You may then press ESCAPE, or select other characteristics for change.

When you have finished editing the attributes of the selected volume, the volume's new attributes are displayed, and you are asked to confirm the edits:

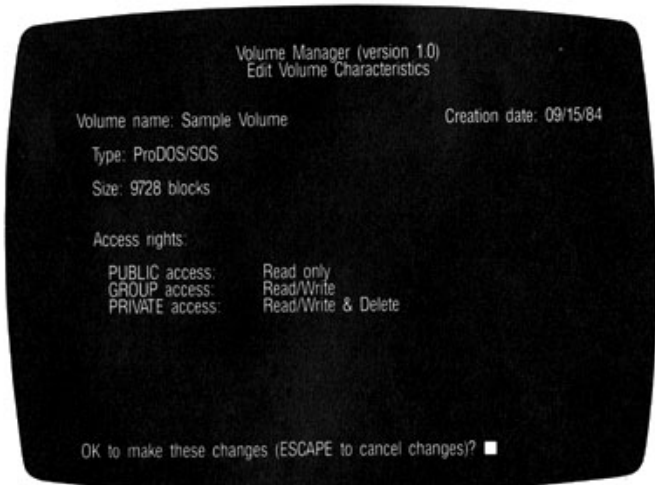

If you enter "YES" or simply press RETURN, all changes you made are applied to the volume. If you press ESCAPE, all changes you have made to the volume will be canceled. If you enter a negative response instead, you are given the chance to make further changes to the volume.

7. Utilities

The seventh entry on the Volume Manager main menu allows you to perform utility functions on your QC hard disk system. When you select this entry, you are requested to enter the current system master password.

You are then presented with a screen from which you may select the desired utility function. Currently, the only utility function available allows the system master password to be changed. Since this is the case, enter "1".

You may then enter the new system master password, used to gain full access to any volume. It is strongly suggested that the initial master password ("MASTER") be changed if you desire to restrict access to any of your volumes.

8. Quit

The last entry on the Volume Manager main menu is used to exit the program.

Macintosh Volume Manager

To run the Volume Manager program, start up your Macintosh with the disk labeled "Macintosh Software". Use the mouse to move the pointer over the Volume Manager icon, and double-click the mouse button. The program will begin, displaying a screen similar to the following:

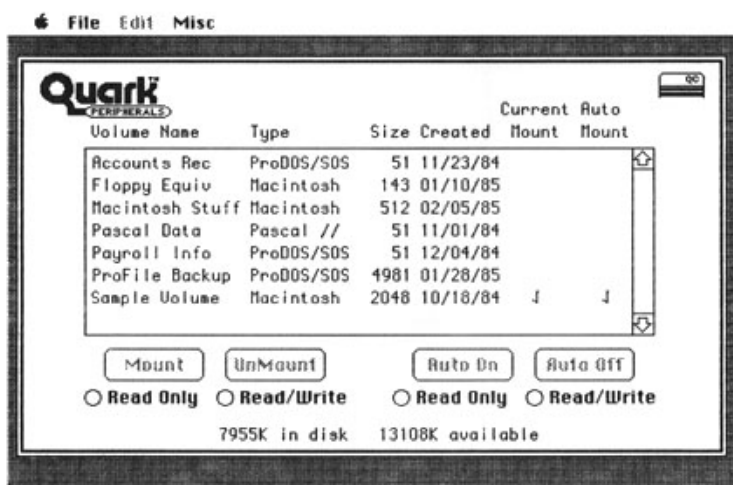

The menu entries at the top of the screen may be selected by moving the pointer over the desired entry, and dragging the pointer downward while depressing the mouse button.

The large rectangular box in the middle of the screen shows a "Catalog of Volumes", listing all volumes in alphabetical order currently defined on your QC hard disk. Each entry shows the volume's name, volume type, size, date created, and indicators showing whether the volume is currently mounted, or is automatically mounted at system power up.

If your hard disk has more volumes than can be displayed on the screen, you may use the scroll bar on the right of the rectangular box to view the remaining volumes.

The total amount of storage (in units of 1K, 1000 bytes or characters) used on the hard disk, and the amount of free storage remaining are shown at the bottom of the screen.

If your hard disk contains any damaged volumes, a message to that effect will be displayed in the "Catalog of Volumes".

Creating New Volumes

The QC hard disk system will allow up to 63 different volumes to be created. By pulling down the "File" menu entry with the mouse, the "Create Volume" option may be selected. This option may also be selected by holding down the Command key and pressing "N" (for "New").

When you select the "Create Volume" option, you are presented with a dialog box, similar to the following:

Volume Name: <input type="text"/>	Volume Type: <input type="radio"/> ProDOS/SOS <input type="radio"/> Pascal // <input checked="" type="radio"/> Macintosh <input type="radio"/> Other: <input type="text"/>	<input type="button" value="OK"/> <input type="button" value="Cancel"/>
Volume Size: <input type="text"/> K		
Access Restrictions: Full access allowed.		
Public: <input type="radio"/> None <input type="radio"/> Read <input checked="" type="radio"/> Read/Write <input checked="" type="checkbox"/> Delete		
Group: <input checked="" type="radio"/> None <input type="radio"/> Read <input type="radio"/> Read/Write <input type="checkbox"/> Delete		
Private: <input checked="" type="radio"/> None <input type="radio"/> Read/Write <input type="checkbox"/> Delete		

As illustrated above, four things must be taken into consideration when creating a new volume:

- Volume name
- Volume size
- Volume type
- Access restrictions

When the dialog box appears, a text insertion bar will begin blinking in the volume name field. Type the name for your new volume in this field.

Press the Tab key (or use the mouse to move the pointer to the volume size field, and click the mouse button), and the text insertion bar will begin blinking in the volume size field. Here you must specify the size of your new volume in units of 1K (1000 bytes or characters).

The size you specify will depend on what you intend to use the volume for and how much room is left on your hard disk. Volumes must be at least 33K in size. A floppy diskette on the Apple //c, //e, and /// computers will hold about 143K. On the Macintosh, a single floppy can hold 410K.

One megabyte is approximately 1000K. If you wish to configure your hard disk as one gigantic volume, delete all remaining volumes on the disk (first, make sure that you really don't need them). The "Catalog of Volumes" will show the total amount of storage available on the disk.

The volume type entries may be selected by using the mouse to move the pointer over the desired entry's "radio button", and clicking the mouse button. You will note that the "Macintosh" entry has been pre-selected, since you will probably use this selection most of the time. If you click on the "Other" entry, you must enter your own volume type in the field's corresponding box.

The volume's access restrictions may be entered by clicking on the appropriate radio buttons. You will note that these entries have been pre-selected to assume an unrestricted volume, with Read/Write and Delete for PUBLIC access, and None for GROUP and PRIVATE access. The Delete box automatically notes which level of access receives Delete access.

After supplying the characteristics for the new volume, click the "OK" button (or simply press RETURN) to confirm the creation of the volume. If you decide that you really don't want to create the volume, click the "Cancel" button.

Note that the Macintosh will ask if you want to initialize (erase) your newly created volume the first time it is mounted for access. You must initialize a volume before you can store files on it.

Editing Current Mounts

The "Mount" and "UnMount" buttons (directly below the "Catalog of Volumes" box on the Volume Manager screen) allow you to selectively make volumes available or unavailable for access by your system. The number of individual volumes that may be mounted at one time is limited only by the amount of memory in your system.

To mount or unmount a volume, use the mouse to position the pointer over the desired volume in the "Catalog of Volumes" box. Click the mouse button once to select that entry, and the line is highlighted. What was black is now white and vice versa.

If the selected volume is already mounted (indicated by a check mark in the "Current Mount" column), the "Mount" button will be dimmed, and the "radio button" indicators directly below "Mount" and "UnMount" will show what accesses are currently available on the volume (Read Only or Read/Write). You may change these accesses by clicking on the radio buttons. To disconnect the selected volume from the system, click the "Unmount" button.

If the selected volume is not mounted, the "UnMount" button will be dimmed. Click the appropriate "radio button" indicator to select the accesses to be made available on the volume.

Next click the "Mount" button to actually connect the selected volume for access by your system. If you do not select the mount accesses before clicking on the "Mount" button, you will be asked for them.

If the volume has access restrictions, you will be asked for the password necessary to grant the accesses you request through the radio buttons. If you supply an incorrect password, the selected volume is left unaltered.

Be careful when mounting a volume whose volume type is not "Macintosh". When you mount non-Macintosh type volumes, the Mac automatically asks that they be initialized (erased).

Editing Automatic Mounts

The "Auto On" and "Auto Off" buttons (below the "Catalog of Volumes" box on the Volume Manager screen) allow you to specify those volumes to be automatically mounted when your Macintosh is first started up. A maximum of four volumes may be marked for automatic mounting.

The procedure for changing your automatic mounts is the same as that described above for editing current mounts, with the "Auto On" and "Auto Off" buttons (and their associated "radio button" indicators) being used instead of "Mount" and "UnMount".

Note that changing automatic mounts only affects the volumes to be attached when your system is first started up. Your current mounts are unaffected when you edit automatic mounts.

Deleting Volumes

Previously defined volumes may be easily removed from the QC hard disk system. All storage associated with a volume is released when that volume is deleted. The freed storage is then available for use by any subsequent volume definitions.

To delete a volume, first select it by using the mouse to position the pointer over the desired volume in the "Catalog of Volumes" box. Click the mouse button once to select that entry, and the line is highlighted. What was black is now white and vice versa.

Next, pull down the "File" menu entry with the mouse and select the "Delete Volume" option. Alternatively, you may hold the Command key and press "D" (for "Delete"). An alert box will appear, showing the characteristics of the selected volume, and requesting you to confirm the deletion.

If you click the "OK" button (or simply press RETURN), the volume will be deleted and its storage released into the free disk space. If you decide that you really don't want to delete the volume, you may click the "Cancel" button.

If the volume has access restrictions, you will be asked for the password necessary to grant "Delete" access. If an incorrect password is supplied, the volume is not deleted.

Note that you may not delete a volume if it is currently mounted. If you attempt to delete a volume which has been set up as an automatic mount (for any system), you will receive a warning message and be given the opportunity to abort the volume deletion.

Editing Volume Characteristics

The attributes associated with a given volume, including volume name, volume type and access restrictions may be easily changed through the Volume Manager.

To change the size of a volume, you must create a new volume with your desired size, copy all information from the old volume to the new one, and then delete the old volume. Finally, you may wish to change the name of the new volume to that of the old.

To change the other attributes of a volume, first select the volume by using the mouse to position the pointer over the desired volume in the "Catalog of Volumes" box. Click the mouse button once to select that entry, and the line is highlighted. What was black is now white and vice versa.

Next, pull down the "Edit" menu entry with the mouse and select the "Volume Characteristics" option. Alternatively, you may hold the Command key and press "E" (for "Edit"). A box appears, showing the characteristics of your selected volume. If the volume has restricted access, you are asked to supply the password necessary to grant "Delete" access.

Volume Name: <input type="text" value="Sample Volume"/>	Volume Type: <input type="radio"/> ProDOS/SOS <input type="radio"/> Pascal // <input checked="" type="radio"/> Macintosh <input type="radio"/> Other: <input type="text"/>	<input type="button" value="OK"/> <input type="button" value="Cancel"/>
Volume Size: <input type="text" value="2048"/> K		
Access Restrictions: Full access allowed.		
Public: <input type="radio"/> None <input type="radio"/> Read <input checked="" type="radio"/> Read/Write	<input checked="" type="checkbox"/> Delete	
Group: <input checked="" type="radio"/> None <input type="radio"/> Read <input type="radio"/> Read/Write	<input type="checkbox"/> Delete	
Private: <input checked="" type="radio"/> None <input type="radio"/> Read/Write	<input type="checkbox"/> Delete	

The volume characteristics box may be used to edit the current attributes of the selected volume. When you finish editing these attributes, click the "OK" button (or simply press RETURN) to confirm your edits. If you click the "Cancel" button instead, all changes you have made to the selected volume will be ignored.

A volume's characteristics may also be changed by using the mouse to position the pointer over the desired volume in the "Catalog of Volumes" box, and then double-clicking the mouse button to select the entry for editing.

Miscellaneous Functions

The "Misc" menu entry on the Volume Manager display includes a function not yet addressed: "Change Master Password". This option may also be selected by holding the Command key and pressing "P" (for "Password").

The "Change Master Password" option allows you to specify a new master password for the hard disk system. The master password (initially, "MASTER") may be used to gain full access to any volume. It is strongly suggested that the initial system master password be changed if you desire to restrict access to any of your volumes.

This option will request that you enter the old system master password before allowing you to change it.

Quit

The "Quit" option under the "File" menu entry on the Volume Manager display is used to exit the program. You may also select the Quit option by holding the Command key and pressing "Q" (for "Quit").

Desk Accessories

Macintosh desk accessories, (the Scrapbook, Alarm Clock, Note Pad, Calculator, etc.) are available for use while in the Volume Manager. Desk accessories may be selected from the Apple menu on the left side of the menu bar.

Note that while a desk accessory is active, the Volume Manager's "Edit" menu (containing the Volume Characteristics entry) is replaced with the Macintosh's conventional "Edit" menu: (Undo, Cut, Copy, Paste and Clear). These functions are then available for use with the desk accessories.

To reselect the Volume Manager when a desk accessory is active, simply use the mouse to move the pointer over an area of the Volume Manager's window, and click the mouse button. Any active desk accessories will be moved behind the Volume Manager's window. Alternatively, you may remove all desk accessories by clicking the mouse in each accessory's close box.

Apple IIc, IIe and III Volume Manager

An error is denoted by the flashing word ERROR in the lower left hand corner of the screen. To clear an error condition, press the ESCAPE key.

Directory damage too extensive

There is enough free space on the hard disk to create your volume, however, the free space cannot be reorganized due to the existence of damaged volume(s). Use the "Catalog of Volumes" option to find out which volume(s) are damaged. Save as much information as you can from the damaged volume(s), and then delete them.

Disk full

There is not enough space on your hard disk to create your volume. You may wish to retry the operation specifying a smaller size for the new volume.

Duplicate volume

You have attempted to create a volume whose name already exists in the table of currently defined volumes. You must enter a unique volume name when creating a volume.

Improper password

You have entered an incorrect password for a volume. Retry the operation and specify the correct password for the volume in question.

No such volume

The volume name you have entered does not match any of those currently defined on your hard disk. Verify your entry with the list of defined volume names and retry the operation.

QC hard disk not connected

This message is self explanatory.

Unsupported volume interleave

You are using an outdated version of the Volume Manager. Contact Quark to obtain the latest version.

Volume currently mounted

You may not delete a volume which is mounted. Unmount it first.

Volume directory full

The QC hard disk system supports up to 63 volumes. You have attempted to exceed this limit.

Volume in use

You have attempted to mount a volume which is already mounted. If you wish to move the specified volume to a different device or drive, it must first be unmounted from the device or drive on which it is currently mounted.

In addition to the above errors, you may encounter the following message, displayed in the center of your screen:

QC hard disk driver not installed

This message will appear if your QC hard disk was not powered up or connected to your system when you started up the Volume Manager. It will also appear if, for some reason, the QC hard disk drivers are not present on your Volume Manager diskette.

Apple IIc and IIe QC Hard Disk Utilities

An error is denoted by the flashing word ERROR in the lower left hand corner of the screen. To clear an error condition, press the ESCAPE key.

Bad QC driver file

The hard disk driver file on your application boot diskette is bad.

Can't install driver

The diskette onto which you are attempting to install the hard disk drivers has a QC.DRIVER or DRIVER.SYSTEM file not created by Quark.

Directory damaged

The directory you have attempted to access has been destroyed by unknown forces inimical to magnetic media. You should strongly consider using your backup in place of the damaged diskette. You may wish to salvage as many good files from the diskette as you can by copying them to a new diskette, and then copy the files that were lost from your backup.

Directory full

You have attempted to store more files in the main directory on your diskette than are allowed (only 51 are allowed). Installing the QC hard disk drivers places two files on your diskette. You will have to use the "Start Application" option to load the drivers into memory before starting up your application program, if you are unable to make room for the drivers on your application boot diskette.

Disk full

There is not enough space left on your diskette to store your QC hard disk drivers. You will have to remove some files on the diskette before you will be able to write the drivers to the diskette, or use the "Start Application" option to load the drivers into memory before starting up your application program.

File locked

The file you were attempting to delete or update has been locked by a LOCK command from BASIC. You will not be able to delete or update the file unless you unlock it.

File not found

A file required by the QC Hard Disk Utilities program has been accidentally deleted on your "ProDOS/SOS Software" diskette.

I/O error

The diskette has a "bad" spot on it which ProDOS cannot read. Occasionally this error occurs as a result of an improperly centered diskette. You may wish to try opening the door on the drive giving the error and closing it again (without removing the diskette). This recenters the diskette. You may then be able successfully repeat the operation.

More than one SYSTEM file on boot diskette

You have attempted to Install Drivers or Start an Application, but the application boot diskette in the internal drive has more than one ".SYSTEM" file.

No QC hard disk driver on this diskette

You have attempted to Edit Slot/Drive Assignments on an application boot diskette containing no QC hard disk driver file.

Not ProDOS disk

The disk you have attempted to access is not formatted like a normal ProDOS diskette. It is probably a disk formatted using either DOS 3.3 or Pascal.

ProDOS error \$dd

The two characters following the "\$" represent a hexadecimal number corresponding to a ProDOS error with which the Utilities program is unfamiliar. Record the number and the circumstances surrounding the failure. If the problem persists after retrying the procedure, report the failure to Quark.

SYSTEM file locked

You have attempted to Install Drivers, but the ".SYSTEM" file on the application boot diskette in the internal drive is locked.

SYSTEM file not found

You have attempted to Install Drivers or Start an Application, but the application boot diskette you have in the internal drive does not have a ".SYSTEM" file.

Volume not found

The "ProDOS/SOS Software" diskette was not inserted in a diskette drive when you attempted to use the Volume Manager or Filer.

Write protected diskette

You have attempted to Install or Edit the QC hard disk drivers on a diskette having a write protect tab. Remove the tab, and retry the procedure.

Macintosh Volume Manager

Macintosh error messages appear in an alert box. To acknowledge an error, use the mouse to position the pointer over the "OK" button, and click the mouse button.

The text of each error message follows. The messages are self-explanatory.

- "nnnnn" is the startup disk. You may not unmount it.
- Internal system tables are damaged. It is recommended that you restart your Macintosh.
- The QC hard disk driver is not installed. Open the application named QC STARTUP, or restart your Macintosh with the Quark "Macintosh Software" disk.
- The QC hard disk is not connected. Connect it, power it up, wait 30 seconds, and then click "OK". "Cancel" returns you to the Finder.
- The name "nnnnn" is already used. Use a different name.
- The space on the QC hard disk is too fragmented to create this volume. Try creating it with a smaller size.
- The volume size must be between 33K and nnK, the amount of space left on the disk. Please enter a size in this range.
- There is not enough memory to mount this volume. Try unmounting another one first.
- This is not a Macintosh disk. You must mount it with Read/Write access for it to be initialized.
- This volume is set up to automatically mount. OK to delete it anyway?
- Unable to read directory of QC hard disk.
- Unable to write directory of QC hard disk.

- You are using an outdated version of the Volume Manager which can't access this volume.
- You have entered an incorrect password. Retry the operation with the correct password.